

# S-QUAD SELF-TEST (S4T) SERIES

Multi-Sensors with additional Sounder, Voice & VAD variants

S-Quad's market leading technology advances even further with our Self-Test series of detectors (S4T). The S4T device is a brand-new design which incorporates all the great S-Quad features and more.

The device has a new IP21 external moulding, new detector chamber design and a dual microprocessor PCB. This design delivers even better smoke detection and voice storage capacity. In addition, the award-winning Self-Test feature allows both the heat and optical sensors within the device to be tested using the CLSS app.

The Self-Test patented design performs real sensor tests by heating the heat sensing thermistor and generating real aerosol (smoke) to test the optical sensor. The small fan within the device gently blows the aerosol from the detection chamber, through the detector's smoke entry points, into the room. This method simulates a more realistic fire test than many traditional testing methods, ensuring that the smoke entry points are not blocked and able to detect a real fire.

Each device also incorporates Bluetooth Low Energy (BLE). When activated, BLE acts like a beacon in each detector that can be automatically detected by a mobile device using the CLSS app. This has many helpful features such as finding a device automatically, ensuring the device details are correct and proving that an engineer has been within the visual inspection range.



## KEY SELF-TEST & CLSS FEATURES

- Available in a large range of multi-sensor, Part-23 VAD and sounder/ voice options.
- Enables discrete functional testing and visual inspection of the fire alarm system by reducing the engineer toolset to just a mobile device (phone or tablet). No more impact on building occupiers.
- Tests both the heat and smoke sensors by heating the thermistor and introducing small amounts of smoke into the detection chamber.
- Gently blows the smoke out of the detection chamber and smoke entry points to ensure they are not blocked.
- Flexible testing options allow the engineer to test in different ways – single device, detection zone, loop(s), panel(s).
- Allows up to 6 devices to be tested at once per loop and any number of loops can be tested simultaneously, making the functional testing incredibly fast.
- Device testing is fast enough to allow up to 4 functional tests to be performed per year for the lifespan of the device.
- Eliminates all access issues when detector testing, ensuring 100% functional testing is achieved.
- Allows the system to remain active whilst testing as each detector is only offline for 60 seconds and outputs are not generated.
- Any fires detected outside of the devices performing Self-Test will stop the Self-Test process and operate the fire systems Cause & Effect.
- Allows the engineer to easily locate the detector using the App and BLE to check the device number, label, zone description and detector type.
- Allows simple device updates to be performed through the App, including the correction of inaccurate device labels and loop mapping.
- The app and BLE handshake verifies that the engineer has been within visual inspection range.
- Optional Inspection prompt LEDs on the device let the engineer know what Self-Test devices need to be visually inspected and will automatically turn off when the visual inspection is complete.
- Engineers can spend more time digitally capturing non-compliance issues and advising how to resolve them. This includes any issues causing false alarms.
- Test Fire LED option in the App allows the fire LED to be tested (a pending BS5839-1 testing requirement). This feature can additionally confirm that they are inspecting the correct device.
- The CLSS App allows the engineer to simulate a fire and test the Cause & Effect logic.
- The CLSS App also allows the Cause & Effect to be triggered through a successful Self-Test operation, allowing a witness test to be performed using real smoke.

## SYSTEM REQUIREMENTS

- Self-Test features compatible with Vigilon and Compact Plus panels only.
- MCB / MCC and loop cards will require firmware upgrades to operate Self-Test and BLE features.
- Only supported on current EN54 loop cards (not legacy loop cards).
- Requires a CLSS gateway (1 per network domain).
- Requires the CLSS mobile app.

## REPORTING AND MONITORING

- A full compliance report can be generated on completion of the testing.
- The number of Self-Test's consumed per device is captured through CLSS, enabling a quick check of usage.
- Reports identify how devices have been tested – manually or through Self-Test.
- Reports identify how the device was visually inspected, with or without BLE.
- Any corrective actions are also captured in the reports.

## S-QUAD SELF TEST PRODUCT RANGE

PART NUMBER	DESCRIPTION
S4T-720	S4 SELF-TEST Heat Sensor
S4T-710	S4 SELF-TEST Optical Heat Sensor
S4T-711	S4 SELF-TEST Dual Optical Heat Sensor
S4T-780-S	S4 SELF-TEST Heat Sensor Sounder
S4T-770-S	S4 SELF-TEST Optical Heat Sensor & Sounder
S4T-771-S	S4 SELF-TEST Dual Optical Heat Sensor & Sounder
S4T-711-V	S4 SELF-TEST Dual Optical Heat Sensor & Voice Sounder
S4T-711-VAD-HPR	S4 SELF-TEST Dual Optical Heat Sensor & High Power Red VAD
S4T-720-V-VAD-HPR	S4 SELF-TEST Heat Sensor, Voice Sounder & High Power Red VAD
S4T-711-V-VAD-HPR	S4 SELF-TEST Dual Optical Heat Sensor, Voice Sounder & High Power Red VAD
S4TB-711-V-VAD-HPR	S4 SELF-TEST Black Dual Optical Heat Sensor, Voice Sounder & High Power Red VAD

## ASSOCIATED PRODUCTS

PART NUMBER	DESCRIPTION
S4-700	Base (for all SELF-TEST Sensors)
S4BK-700	Black Base for Black S-Quad SELF-TEST
S4-705	White IP21C plate
S4BK-705	Black IP21C plate
805589	Sensor dust cover (50 pack)
805580	Removal tool kit (supplied with Dust Cover Remover part)
805576	Label plate (10 pack)

Please note: If you require detailed information regarding light coverage, please refer to the S-Quad Data and Installation Guide available from Gent Expert and InfoPoint.

## APPROVALS

- Approvals - EN54, LPCB, UKCA and CE.
- The first detector to ever be EN54 tested and approved after the completion of heat and smoke maintenance testing.
- Compliant to BS3589-1 testing standards.

## LIST OF PATENTS

- H218226-GB
- H218226-DE
- H218226-FR
- H218226-EP
- H218226-US-CON
- H218226-CN
- H213983-US-CON
- H213983-CN
- H222549-US
- H221422-US
- H220104-US
- H219291-US

# S-Quad Self-Test Multi-sensor with Integrated Sounder and Visual Alarms

## Technical Specifications

### GENERAL SPECIFICATION

Operating voltage	35V - 48V
Weight	Sensor head only: 152 g (with Standard base - 212 g)
Dimensions	Sensor head: 117 mm diameter by 63 mm height (with Base the height increases to 70 mm)
IP rating	IP21C
Enclosure	Terluran GP-35 (ABS) for outer housing
Colour	<b>White:</b> RAL 9010 <b>Black:</b> RAL 9005
Approval	LPCB approval, CE & UKCA
Storage Temperature	-20 °C to +65 °C
Ambient operating temperature	-10 °C to +50 °C
Relative Humidity	95 % non-condensing (+5 °C to +45 °C)
Air Velocity for fire detection	0 to 20 m/s

### SELF-TEST (ST) OPERATION

Smoke Self-Test temperature range	0 to 40 °C expected
Heat Self-Test temperature range	0 to 40 °C expected
Maximum number of optical tests	60 (expected maximum of 4 Self-Tests and 4 tests/year for 14 years)
Maximum number of heat tests	100 (expected maximum 4 tests and 4 tests/year for 20 years)
Air Velocity around device	0 to 1.5 m/s
Bluetooth range	10m
Heat (H)	EN54-5: 2017 + A1: 2018
Optical (O)	EN54-7: 2018
Dual Optical (O <sup>2</sup> )	EN54-7: 2018
Sounder (S)	EN54-3: 2001 + A1: 2002 + A2: 2006 EN54-3: 2014 + A1: 2019
Visual Alarm Device (VAD)	EN54-23: 2010
Input/Output devices connected to transmission path	EN54-18: 2005
Short circuit isolator EN54-17: 2005 (section 4.8) data	V <sub>max</sub> 48 V      IC max 0.8 A V <sub>nom</sub> 40 V      IS max 1.25 A V <sub>min</sub> 35 V      IL max 50 uA V <sub>so</sub> max 16 V      Z <sub>c</sub> max 0.13 Ω V <sub>so</sub> min 8 V
Sounder current	2 mA average and 4.5 mA maximum in Turbo mode (Refer to Battery Standby and Loop Load Calculator Tool.)

### DIMENSIONS

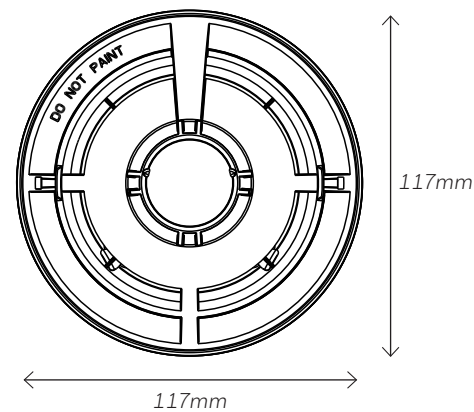
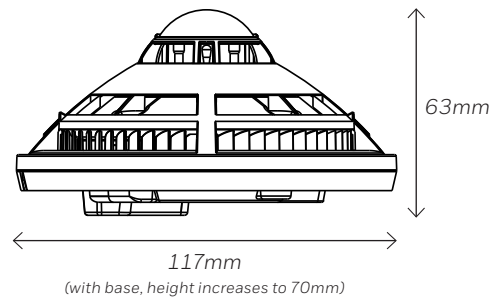

### FIND OUT MORE



### Honeywell Gent

Carlton Park  
Narborough  
Leicestershire  
LE19 0LF

www.gent.co.uk

SQST-CWA | Rev1 | 07/23  
© 2023 Honeywell International Inc.

**Honeywell**  
GENT