

Emergency Communication System

ECS Series

Manual

Fire Alarm & Emergency Communication System Limitations

While a life safety system may lower insurance rates, it is not a substitute for life and property insurance!

An automatic fire alarm system—typically made up of smoke detectors, heat detectors, manual pull stations, audible warning devices, and a fire alarm control panel (FACP) with remote notification capability—can provide early warning of a developing fire. Such a system, however, does not assure protection against property damage or loss of life resulting from a fire.

An emergency communication system—typically made up of an automatic fire alarm system (as described above) and a life safety communication system that may include an autonomous control unit (ACU), local operating console (LOC), voice communication, and other various interoperable communication methods—can broadcast a mass notification message. Such a system, however, does not assure protection against property damage or loss of life resulting from a fire or life safety event.

The Manufacturer recommends that smoke and/or heat detectors be located throughout a protected premises following the recommendations of the current edition of the National Fire Protection Association Standard 72 (NFPA 72), manufacturer's recommendations, State and local codes, and the recommendations contained in the Guide for Proper Use of System Smoke Detectors, which is made available at no charge to all installing dealers. This document can be found at <http://www.systemsensor.com/appguides/>. A study by the Federal Emergency Management Agency (an agency of the United States government) indicated that smoke detectors may not go off in as many as 35% of all fires. While fire alarm systems are designed to provide early warning against fire, they do not guarantee warning or protection against fire. A fire alarm system may not provide timely or adequate warning, or simply may not function, for a variety of reasons:

Smoke detectors may not sense fire where smoke cannot reach the detectors such as in chimneys, in or behind walls, on roofs, or on the other side of closed doors. Smoke detectors also may not sense a fire on another level or floor of a building. A second-floor detector, for example, may not sense a first-floor or basement fire.

Particles of combustion or "smoke" from a developing fire may not reach the sensing chambers of smoke detectors because:

- Barriers such as closed or partially closed doors, walls, chimneys, even wet or humid areas may inhibit particle or smoke flow.
- Smoke particles may become "cold," stratify, and not reach the ceiling or upper walls where detectors are located.
- Smoke particles may be blown away from detectors by air outlets, such as air conditioning vents.
- Smoke particles may be drawn into air returns before reaching the detector.

The amount of "smoke" present may be insufficient to alarm smoke detectors. Smoke detectors are designed to alarm at various levels of smoke density. If such density levels are not created by a developing fire at the location of detectors, the detectors will not go into alarm.

Smoke detectors, even when working properly, have sensing limitations. Detectors that have photoelectronic sensing chambers tend to detect smoldering fires better than flaming fires, which have little visible smoke. Detectors that have ionizing-type sensing chambers tend to detect fast-flaming fires better than smoldering fires. Because fires develop in different ways and are often unpredictable in their growth, neither type of detector is necessarily best and a given type of detector may not provide adequate warning of a fire.

Smoke detectors cannot be expected to provide adequate warning of fires caused by arson, children playing with matches (especially in bedrooms), smoking in bed, and violent explosions (caused by escaping gas, improper storage of flammable materials, etc.).

Heat detectors do not sense particles of combustion and alarm only when heat on their sensors increases at a predetermined rate or reaches a predetermined level. Rate-of-rise heat detectors may be subject to reduced sensitivity over time. For this reason, the rate-of-rise feature of each detector should be tested at least once per year by a qualified fire protection specialist. Heat detectors are designed to protect property, not life.

IMPORTANT! Smoke detectors must be installed in the same room as the control panel and in rooms used by the system for the connection of alarm transmission wiring, communications, signaling, and/or power. If detectors are not so located, a developing fire may damage the alarm system, compromising its ability to report a fire.

Audible warning devices such as bells, horns, strobes, speakers and displays may not alert people if these devices are located on the other side of closed or partly open doors or are located on another floor of a building. Any warning device may fail to alert people with a disability or those who have recently consumed drugs, alcohol, or medication. Please note that:

- An emergency communication system may take priority over a fire alarm system in the event of a life safety emergency.
- Voice messaging systems must be designed to meet intelligibility requirements as defined by NFPA, local codes, and Authorities Having Jurisdiction (AHJ).
- Language and instructional requirements must be clearly disseminated on any local displays.
- Strobes can, under certain circumstances, cause seizures in people with conditions such as epilepsy.
- Studies have shown that certain people, even when they hear a fire alarm signal, do not respond to or comprehend the meaning of the signal. Audible devices, such as horns and bells, can have different tonal patterns and frequencies. It is the property owner's responsibility to conduct fire drills and other training exercises to make people aware of fire alarm signals and instruct them on the proper reaction to alarm signals.
- In rare instances, the sounding of a warning device can cause temporary or permanent hearing loss.

A life safety system will not operate without any electrical power. If AC power fails, the system will operate from standby batteries only for a specified time and only if the batteries have been properly maintained and replaced regularly.

Equipment used in the system may not be technically compatible with the control panel. It is essential to use only equipment listed for service with your control panel.

Alarm Signaling Communications:

- **IP connections** rely on available bandwidth, which could be limited if the network is shared by multiple users or if ISP policies impose restrictions on the amount of data transmitted. Service packages must be carefully chosen to ensure that alarm signals will always have available bandwidth. Outages by the ISP for maintenance and upgrades may also inhibit alarm signals. For added protection, a backup cellular connection is recommended.
- **Cellular connections** rely on a strong signal. Signal strength can be adversely affected by the network coverage of the cellular carrier, objects and structural barriers at the installation location. Utilize a cellular carrier that has reliable network coverage where the alarm system is installed. For added protection, utilize an external antenna to boost the signal.
- **Telephone lines** needed to transmit alarm signals from a premise to a central monitoring station may be out of service or temporarily disabled. For added protection against telephone line failure, backup alarm signaling connections are recommended.

The most common cause of life safety system malfunction is inadequate maintenance. To keep the entire life safety system in excellent working order, ongoing maintenance is required per the manufacturer's recommendations, and UL and NFPA standards. At a minimum, the requirements of NFPA 72 shall be followed. Environments with large amounts of dust, dirt, or high air velocity require more frequent maintenance. A maintenance agreement should be arranged through the local manufacturer's representative. Maintenance should be scheduled as required by National and/or local fire codes and should be performed by authorized professional life safety system installers only. Adequate written records of all inspections should be kept.

Limit-F-2020

Installation Precautions

Adherence to the following will aid in problem-free installation with long-term reliability:

WARNING - Several different sources of power can be connected to the fire alarm control panel. Disconnect all sources of power before servicing. Control unit and associated equipment may be damaged by removing and/or inserting cards, modules, or interconnecting cables while the unit is energized. Do not attempt to install, service, or operate this unit until manuals are read and understood.

CAUTION - System Re-acceptance Test after Software Changes:

To ensure proper system operation, this product must be tested in accordance with NFPA 72 after any programming operation or change in site-specific software. Re-acceptance testing is required after any change, addition or deletion of system components, or after any modification, repair or adjustment to system hardware or wiring. All components, circuits, system operations, or software functions known to be affected by a change must be 100% tested. In addition, to ensure that other operations are not inadvertently affected, at least 10% of initiating devices that are not directly affected by the change, up to a maximum of 50 devices, must also be tested and proper system operation verified.

This system meets NFPA requirements for operation at 0-49° C/32-120° F and at a relative humidity 93% ± 2% RH (non-condensing) at 32°C ± 2°C (90°F ± 3°F). However, the useful life of the system's standby batteries and the electronic components may be adversely affected by extreme temperature ranges and humidity. Therefore, it is recommended that this system and its peripherals be installed in an environment with a normal room temperature of 15-27° C/60-80° F.

Verify that wire sizes are adequate for all initiating and indicating device loops. Most devices cannot tolerate more than a 10% I.R. drop from the specified device voltage.

Like all solid state electronic devices, this system may operate erratically or can be damaged when subjected to lightning induced transients. Although no system is completely immune from lightning transients and interference, proper grounding will reduce susceptibility. Overhead or outside aerial wiring is not recommended, due to an increased susceptibility to nearby lightning strikes. Consult with the Technical Services Department if any problems are anticipated or encountered.

Disconnect AC power and batteries prior to removing or inserting circuit boards. Failure to do so can damage circuits.

Remove all electronic assemblies prior to any drilling, filing, reaming, or punching of the enclosure. When possible, make all cable entries from the sides or rear. Before making modifications, verify that they will not interfere with battery, transformer, or printed circuit board location.

Do not tighten screw terminals more than 9 in-lbs. Over-tightening may damage threads, resulting in reduced terminal contact pressure and difficulty with screw terminal removal.

This system contains static-sensitive components. Always ground yourself with a proper wrist strap before handling any circuits so that static charges are removed from the body. Use static suppressive packaging to protect electronic assemblies removed from the unit.

Units with a touchscreen display should be cleaned with a dry, clean, lint free/microfiber cloth. If additional cleaning is required, apply a small amount of Isopropyl alcohol to the cloth and wipe clean. Do not use detergents, solvents, or water for cleaning. Do not spray liquid directly onto the display.

Follow the instructions in the installation, operating, and programming manuals. These instructions must be followed to avoid damage to the control panel and associated equipment. FACP operation and reliability depend upon proper installation.

Precau-D2-11-2017

FCC Warning

WARNING: This equipment generates, uses, and can radiate radio frequency energy and if not installed and used in accordance with the instruction manual may cause interference to radio communications. It has been tested and found to comply with the limits for class A computing devices pursuant to Subpart B of Part 15 of FCC Rules, which is designed to provide reasonable protection against such interference when devices are operated in a commercial environment. Operation of this equipment in a residential area is likely to cause interference, in which case the user will be required to correct the interference at his or her own expense.

Canadian Requirements

This digital apparatus does not exceed the Class A limits for radiation noise emissions from digital apparatus set out in the Radio Interference Regulations of the Canadian Department of Communications.

Le présent appareil numérique n'émet pas de bruits radioélectriques dépassant les limites applicables aux appareils numériques de la classe A prescrites dans le Règlement sur le brouillage radioélectrique édicté par le ministère des Communications du Canada.

Farenhyt™ is a trademark; and Flexput®, Honeywell®, JumpStart®, Silent Knight® and SWIFT® are registered trademarks of Honeywell International Inc. Microsoft® and Windows® are registered trademarks of the Microsoft Corporation. Chrome™ and Google™ are trademarks of Google Inc. Firefox® is a registered trademark of The Mozilla Foundation.

©2022 by Honeywell International Inc. All rights reserved. Unauthorized use of this document is strictly prohibited.

Software Downloads

In order to supply the latest features and functionality in fire alarm and life safety technology to our customers, we make frequent upgrades to the embedded software in our products. To ensure that you are installing and programming the latest features, we strongly recommend that you download the most current version of software for each product prior to commissioning any system. Contact Technical Support with any questions about software and the appropriate version for a specific application.

Documentation Feedback

Your feedback helps us keep our documentation up-to-date and accurate. If you have any comments or suggestions about our online Help or printed manuals, you can email us.

Please include the following information:

- Product name and version number (if applicable)
- Printed manual or online Help
- Topic Title (for online Help)
- Page number (for printed manual)
- Brief description of content you think should be improved or corrected
- Your suggestion for how to correct/improve documentation

Send email messages to:

FireSystems.TechPubs@honeywell.com

Please note this email address is for documentation feedback only. If you have any technical issues, please contact Technical Services.

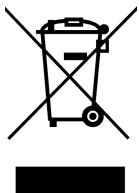

This symbol (shown left) on the product(s) and / or accompanying documents means that used electrical and electronic products should not be mixed with general household waste. For proper treatment, recovery and recycling, contact your local authorities or dealer and ask for the correct method of disposal.

Electrical and electronic equipment contains materials, parts and substances, which can be dangerous to the environment and harmful to human health if the waste of electrical and electronic equipment (WEEE) is not disposed of correctly.

Table of Contents

Section 1: Overview	7
1.1: Compatible ECS Series Equipment	7
1.2: ECS Features	8
1.3: Terms Used in this Manual	8
1.4: Related Documentation	9
Section 2: Agency Listings, Approvals, and Requirements	10
2.1: Federal Communications Commission (FCC)	10
2.2: Underwriters Laboratories (UL)	10
2.2.1: Requirements for All Installations	10
2.2.2: Requirements for Central Station Fire Alarm Systems	10
2.2.3: Requirements for Local Protected Fire Alarm Systems	11
2.2.4: Requirements for Remote Station Protected Fire Alarm Systems	11
2.2.5: Requirements for the Installation of Carbon Monoxide (CO) Detection and Warning Equipment, NFPA 720	11
Section 3: Installation	12
3.1: Environmental Specifications	12
3.2: Wiring Specifications	12
3.3: Cabinet Mounting	12
3.4: Electrical Specifications	13
Section 4: ECS Device Installation	14
4.1: Connecting AC Power and Batteries	14
4.2: Installing the ECS-VCM	14
4.2.1: ECS-VCM Board Layout	14
4.2.2: Installing the ECS-VCM	15
4.2.3: Connecting the ECS-VCM to the SBUS	15
4.2.4: Installing and Connecting the ECS-SW24 to the ECS-VCM	16
4.2.5: Installing the Microphone	17
4.3: Installing the ECS-NVCM	18
4.3.1: ECS-NVCM Board Layout	18
4.3.2: Installing the ECS-NVCM	19
4.3.3: Installing and Connecting the ECS-EMG to the ECS-SW24	19
4.3.4: ECS-NVCM Fiber Modules	21
4.3.5: Installing the Microphone	21
4.4: Installing the ECS-50W	22
4.4.1: ECS-50W Board Layout	23
4.4.2: Mounting the ECS-50W	23
4.4.3: Mounting the ECS-50WBD Board Only	24
4.4.4: Wiring Specifications	25
4.4.5: Speaker Wiring	26
4.4.6: VBUS Wiring	27
4.4.7: SBUS Wiring	28
4.4.8: Connecting AC Power	29
4.4.9: Backup Battery for ECS-50W	30
4.4.10: Calculating Current Draw and Standby Battery	31
4.5: Installing the ECS-INT50W	31
4.5.1: Board Layout & Mounting	31
4.5.2: Wiring to an FACP	32
4.5.3: VBUS Wiring	33
4.5.4: Setting the Device Address	34
4.5.5: Speaker Wiring	34
4.5.6: Calculating Current Draw and Standby Battery	35
4.6: Installing the ECS-125W	35
4.6.1: ECS-125W Board Layout	36
4.6.2: Mounting the ECS-125W	36
4.6.3: Mounting the ECS-125WBD Board Only	37
4.6.4: Wiring Specifications	39
4.6.5: Speaker Wiring	39
4.6.6: VBUS Wiring	41
4.6.7: SBUS Wiring	42
4.6.8: Connecting AC Power	42

4.6.9: Backup Battery for ECS-125W	43
4.6.10: Calculating Current Draw and Standby Battery	43
4.7: Installing the ECS-DUAL50W	44
4.7.1: ECS-DUAL50W Board Layout.....	45
4.7.2: Mounting the ECS-DUAL50W	45
4.7.3: Mounting the ECS-DUAL50WBD Board Only.....	46
4.7.4: Wiring Specifications	48
4.7.5: Speaker Wiring	48
4.7.6: VBUS Wiring	50
4.7.7: SBUS Wiring	52
4.7.8: Setting the ECS-DUAL50W Backup Mode	52
4.7.9: Test Switches	53
4.7.10: Connecting AC Power	53
4.7.11: Backup Battery for ECS-DUAL50W	53
4.7.12: Calculating Current Draw and Standby Battery	54
4.8: Installing the ECS-50WBU	54
4.8.1: ECS-DUAL50W Board Layout.....	55
4.8.2: Installing the ECS-50WBU	55
4.9: Installing the ECS-CE4.....	56
4.10: Installing the ECS-RVM.....	57
4.10.1: ECS-RVM Board Layout	57
4.10.2: Wiring the ECS-RVM	59
4.10.3: Installing the Microphone.....	60
4.10.4: To Remove the ECS-RVM.....	61
4.11: Addressing SBUS Devices.....	61
Panel Security.....	62

Section 1: Overview

The Emergency Communication System Packages are a combination of the addressable fire alarm control panel and voice integration control all in one package. The general idea of the Emergency Communication System is to activate a message giving building occupants instructions about an emergency event. This manual contains information on how to install and operate the following Emergency Communication System Packages:

Model Number	Consists of These Part Numbers
IFP-2100ECS	IFP-2100
	ECS-NVCM (Network Voice Control Module)
ECS-LOC2100	ECS-RVM (Remote Voice Module)
	RA-2000 (Remote Annunciator)
IFP-300ECS	IFP-300
	ECS-NVCM (Network Voice Control Module)
ECS-LOC	ECS-RVM (Remote Voice Module)
	RA-2000 (Remote Annunciator)
IFP-2000ECS	IFP-2000 FACP
	ECS-VCM (Voice control Module)
IFP-1000ECS	IFP-1000 FACP
	ECS-VCM (Voice control Module)
IFP-100ECS	IFP-100 FACP
	ECS-VCM (Voice control Module)

1.1 Compatible ECS Series Equipment

This manual also contains information on how to install the following compatible equipment with the ECS series control panels.

Model Number	Description	Compatible With
ECS-SW24	Adds 24 additional switches to the ECS-VCM, ECS-NVCM, or ECS-RVM to manually select various voice output groups for emergency announcements from the onboard microphone.	IFP-100ECS, IFP-1000ECS, IFP-2000ECS, IFP-300ECS, and IFP-2100ECS
ECS-50W / ECS-50WB ¹	50 watt amplifier with 4 separate audio circuits.	IFP-100ECS, IFP-1000ECS, IFP-2000ECS, IFP-300ECS, and IFP-2100ECS
ECS-125W / ECS-125WB ²	125 watt amplifier with 4 separate audio circuits.	IFP-100ECS, IFP-1000ECS, IFP-2000ECS, IFP-300ECS, and IFP-2100ECS
ECS-CE4	Provides four additional audio circuits for each ECS-50W or ECS-125W.	ECS-50W and ECS-125W
ECS-VCM	Voice Control Module (part of control panel)	IFP-100ECS, IFP-1000ECS, IFP-2000ECS
ECS-NVCM	Network Voice Control Module (part of control panel)	IFP-300ECS and IFP-2100ECS
ECS-RVM	Remote Voice Module (part of ECS-RCU, ECS-LOC and ECS-LOC2100; not sold separately)	IFP-100ECS, IFP-1000ECS, IFP-2000ECS, IFP300ECS, and IFP-2100ECS
ECS-LOC	Local Operating Console	IFP-300ECS
ECS-LOC2100	Local Operating Console	IFP-2100ECS
ECS-RCU	Remote Command Unit	IFP-100 and IFP-1000
ECS-RCU2000	Remote Command Unit	IFP-2000ECS
ECS-DUAL50W / ECS-DUAL50WB ³	Dual 50W Amplifier	IFP-100ECS, IFP-1000ECS, IFP-2000ECS, IFP-300ECS, and IFP-2100ECS
ECS-50WBU	Internal Backup Amplifier (Daughter card)	IFP-100ECS, IFP-1000ECS, IFP-2000ECS, IFP-300ECS, and IFP-2100ECS
ECS-INT50W	50 watt internal amplifier	IFP-100ECS, IFP-1000ECS, IFP-2000ECS, IFP-300ECS, and IFP-2100ECS

1 All references to ECS-50W within this manual are applicable to the ECS-50WB.

2 All references to ECS-50W within this manual are applicable to the ECS-50WB.

3 All references to ECS-DUAL50W within this manual are applicable to ECS-DUAL50WB.

1.2 ECS Features

- Single enclosure for both Fire and Emergency Control System components
- Onboard supervised microphone
- Supports 25 Vrms or 70.7 Vrms speaker circuits using ECS-50W, ECS-INT50W, or ECS-DUAL50W. Supports 25 Vrms using ECS-125W
- Voice Control Module (ECS-VCM) and Network Voice Control Module (ECS-NVCM)
 - IFP-100ECS, IFP-1000ECS, and IFP-2000ECS support one ECS-VCM.
 - IFP-2100ECS or IFP-300ECS support one ECS-NVCM.
 - Built-in Digital Message Repeater
 - 15 one-minute ECS Messages
- IFP-2000ECS, IFP-300ECS, and IFP-2100ECS systems support dual-channel and backup audio using the ECS-DUAL50W amplifier and ECS-50WBU backup amplifier.
- SBUS Addressable Amplifiers
 - IFP-100ECS, IFP-300ECS, and IFP-1000ECS systems support a combination of up to eight ECS-50W, ECS-125W or ECS-DUAL50W amplifiers for a maximum of 1000 watts per system.
 - IFP-2000ECS systems support up to 16 ECS-50W, ECS-125W, or ECS-DUAL50W amplifiers for a maximum of 2000 watts per system.
 - IFP-2100ECS has support for up to 16 ECS-50W, ECS-125W, ECS-INT50W, or ECS-DUAL50W amplifiers for a maximum of 2000 watts per system.
- Local Operator Console (LOC)
 - IFP-100ECS, IFP-300ECS, IFP-1000ECS, and IFP-2000ECS systems can support up to seven ECS-LOC consoles.
 - IFP-2100ECS systems can support up to 15 ECS-2100LOC consoles.
- Mappable Speaker Circuits
 - IFP-100ECS, IFP-300ECS, and IFP-1000ECS systems can support up to 64 mappable speaker circuits using a combination of ECS-50W, ECS-125W, ECS-DUAL50W amplifiers and ECS-CE4 expanders.
 - IFP-2000ECS and IFP-2100ECS systems can support up to 128 mappable speaker circuits using a combination of the ECS-50W, ECS-125W, ECS-DUAL50W, and ECS-INT50W amplifiers, and ECS-CE4 expanders.
- Backup Amplifier
 - ECS-DUAL50W amplifiers are capable of providing 50 watts of backed up audio power with the addition of the ECS-50WBU.
- ECS messages can be selected as priority over fire.
- Programmable trigger inputs from an external source, such as a Monaco system, to the ECS-NVCM, ECS-RVM, 5880, any SLC input module, or Flexput module.

1.3 Terms Used in this Manual

The following terminology is used with the this system:

Term	Description
ECS	Emergency Communication System: The features of the control panel and accessories that provide Mass Notification functionality as described in UL standard 2572.
FACP	Fire Alarm Control Panel
LOC	Local Operator's Console: The user interface for a Mass Notification System. In the Honeywell Farenhyt Series product line, this would be the interface provided by the IFP-100ECS, IFP-1000ECS, IFP-300ECS, IFP-2000ECS, IFP-2100ECS, ECS-LOC, or ECS-LOC2100.
Mass Notification	A way of protecting life by relaying specific event information to a building or site including voice and/or audible and visual signals.
ECS Series	When this is used in a statement, it would indicate the that statement applies to the IFP-2000ECS, IFP-1000ECS, IFP-100ECS, IFP-300ECS, and IFP-2100ECS control panels.
ECS Device	An ECS-LOC or an -5880 module that is programmed as an ECS device. These are used as inputs for triggering the ECS on an IFP-100ECS, IFP-300ECS, IFP-1000ECS, IFP-2000ECS, and IFP-2100ECS.
ECS Control	ECS Control is a mode that all LOC units must enable to change the current state of the ECS system. ECS Control is requested by using the ECS Control Button on LOC stations.
ECS Point	An input point that is programmed to trigger an ECS event on the IFP-2000ECS or IFP-2100ECS.
ECS LOC Priority	The priority level which is programmed for every ECS LOC. In order from lowest to highest, they are: Low, Normal, High.
ECS Super User	A user profile provided option that allows the user to override all ECS Control rules and gain ECS Control.
VBUS	The VBUS is an analog voice bus that carries the recorded voice messages from the ECS-VCM/ECS-NVCM to the ECS-50W, ECS-125W, or ECS-DUAL50W, or the voice messages generated from a system microphone to the ECS-50W, ECS-125W or ECS-DUAL50W.
Module	The term <i>module</i> is used for all hardware devices except for SLC addressable devices and notification appliances.
Main control panel	Refers to the IFP-100ECS, IFP-300ECS, IFP-1000ECS, IFP-2000ECS, or IFP-2100ECS control panel in the ECS Series cabinet.

Term	Description
Input Point	An addressable sensing device, such as a smoke or heat detector or a contact monitor device.
Input Zone	A protected area made up of input points.
Output Point (or Output Circuit)	A notification point or circuit for notification appliances. Relay circuits and auxiliary power circuits are also considered output points. The output group can be specifically defined as an output group to be used for voice evacuation circuits.
Audio Circuits	Are output groups that are defined as voice output groups.
Group (or "Output Group")	A group of output points. Operating characteristics are common to all output points in the group.
Output (or "Cadence") Pattern	The pattern that the output will use, for example, Constant, March Code, ANSI 3.41. Applies to zones and special system events.
Mapping	Mapping is the process of specifying which outputs are activated when certain events occur in the system.

1.4 Related Documentation

Refer to the following documents for more information.

Title	Document Number
IFP-2000ECS Manual	151430-L8
IFP-1000ECS Manual	151460
IFP-100ECS Manual	151458
IFP-300ECS Manual	LS10145-001SK-E
IFP-2100ECS Manual	LS10143-001SK-E
SLC Wiring Manual	LS10179-000FH-E
Device Compatibility Document	LS10167-003FH-E
ECS-RVM Install Sheet	151451
ECS-SW24 Install Sheet	151452
ECS-VCM Install Sheet	151454
ECS-CE4 Install Sheet	151456
ECS-RCU Install Sheet	151457
ECS-INT50W Install Sheet	LS10120-001SK-E
ECS-RPU Install Sheet	LS10152-001SK-E
ECS-NVCM Install Sheet	LS10169-001SK-E
ECS-LOC Install Sheet	LS10187-001SK-E
ECS-LOC2100 Install Sheet	LS10188-001SK-E
ECS-EMG Install Sheet	LS10191-001SK-E

Table 1.1 Related Documentation

Section 2: Agency Listings, Approvals, and Requirements

2.1 Federal Communications Commission (FCC)

1. The following information must be provided to the telephone company before the FACP can be connected to the phone lines:

Manufacturer:	Honeywell Farenhyt
Model Number:	IFP-100ECS, IFP-1000ECS, IFP-2000ECS, IFP-300ECS, IFP-2100ECS
FCC registration number:	AC6USA-34758-AL-E, AC6USA-23901-AL-E or AC6AL11B6820
Ringer equivalence:	0.8B
Type of jack:	RJ31X
Facility Interface Codes:	Loop Start: 02LS2
Service Order Code:	9.0F

2. This device may not be directly connected to coin telephone or party line services.
3. This device cannot be adjusted or repaired in the field. In case of trouble with the device, notify the installing company or return to:
Honeywell
12 Clintonville Road
Northford, CT 06472-1610
203-484-7161 or 800-328-0103
www.farenhyt.com
4. If the FACP causes harm to the telephone network, the telephone company will notify the user in advance that temporary discontinuance of service may be required. If advance notice is not practical, the telephone company will notify the user as soon as possible. Users have the right to file complaints, if necessary, with the Federal Communications Commission.
5. The telephone company may make changes in its facilities, equipment, operations, or procedures that could affect the operation of the equipment. If this happens, the telephone company will provide advance notice to allow you to make the necessary modifications to maintain uninterrupted service.



WARNING: FCC PART 15

THIS DEVICE HAS BEEN VERIFIED TO COMPLY WITH FCC RULES PART 15. OPERATION IS SUBJECT TO THE FOLLOWING CONDITIONS: (1) THIS DEVICE MAY NOT CAUSE RADIO INTERFERENCE, AND (2) THIS DEVICE MUST ACCEPT ANY INTERFERENCE RECEIVED, INCLUDING INTERFERENCE THAT MAY CAUSE UNDESIRED OPERATION.

2.2 Underwriters Laboratories (UL)

2.2.1 Requirements for All Installations

General requirements are described in this section. When installing an individual device, refer to the specific section of the manual for additional requirements. The following subsections list specific requirements for each type of installation (for example, Central Station Fire Alarm systems, Local Protected Fire Alarm systems, and so on). See the Operation Mode Behavior Section of the manual for information on releasing operations.

- ✓ All field wiring must be installed in accordance with NFPA 70 National Electric Code.
- ✓ Use the addressable smoke detectors specified in the *SLC Wiring Manual* and/or conventional detectors listed in the *Device Compatibility Document*.
- ✓ Use UL listed notification appliances compatible with the FACP from those specified in the *Device Compatibility Document*.
- ✓ A full system checkout must be performed any time the panel is programmed.

Restricted Options

- The loss of AC signal is defaulted to 3 hours however the system allows settings from 0 - 3 hours. For UL certified installations this number must be set from 1 to 3 hours.
- The system allows the use of non-latching spot type smoke detectors. This feature may not be used in commercial applications whereby a general alarm is sounded. It is intended for elevator recall, door holding applications, and hotel/motel room applications.
- The system allows the Alarm Verification time to be set from 60 to 255 seconds. For UL certified installations the setting must be a minimum of 60 seconds.
- The system allows the Auto-resound time to be set to 24 or 4 hours. For UL certified installations that are utilizing SWIFT devices, the value must be set to 4 hours.
- Call forwarding shall not be used.
- When two count is used detector spacing shall be cut in half, you shall not use the alarm verification feature, and no delay shall be used.
- P.A.S (positive alarm sequence) feature shall be used only with automatic detectors.

2.2.2 Requirements for Central Station Fire Alarm Systems

- ✓ Use both phone lines. Enable phone line monitors for both lines.
- ✓ You must program a phone number and a test time so that the FACP shall automatically initiate and complete a test signal transmission sequence to its associated receiver at least once every 6 hrs.
- ✓ The AC Loss Hours option must be set from 1-3 hours.
- ✓ If using wired Ethernet or cellular, you must program the corresponding account/subscriber ID and a test time so that the FACP shall automatically initiate a test signal transmission sequence to its associated receiver at least once every 6 hrs.

2.2.3 Requirements for Local Protected Fire Alarm Systems

At least one UL listed supervised notification appliance must be used.

2.2.4 Requirements for Remote Station Protected Fire Alarm Systems

Minimum system requirements are one Honeywell Silent Knight addressable initiating device and either a 5220, Keltron 3158, or the built-in Digital Alarm Communicator Transmitter (DACT).

- ✓ Do not exceed the current load restrictions shown in Section 3 of FACP manual.
- ✓ The AC Loss Hours option must be set from 1-3 hours.

2.2.5 Requirements for the Installation of Carbon Monoxide (CO) Detection and Warning Equipment, NFPA 720

When using carbon monoxide detection, the system must be monitored by a Supervising Station with emergency response, both aspects meeting the Standard for the Installation of Carbon Monoxide (CO) Detection and Warning Equipment, NFPA 720.

Section 3: Installation

This section of the manual is intended to help you plan your tasks to complete the installation. Please read this section thoroughly, especially if you are installing a ECS Series control panel for the first time.

3.1 Environmental Specifications

It is important to protect the ECS panel from water. To prevent water damage, the following precautions should be followed when installing the units:

- Mount in indoor, dry environments only.
- Do not mount directly on exterior walls, especially masonry walls (condensation).
- Do not mount directly on exterior walls below grade (condensation).
- Protect from plumbing leaks.
- Protect from splash caused by sprinkler system inspection ports.
- Do not mount in areas with humidity-generating equipment (such as dryers, production machinery).

When selecting a location to mount the control panel, the unit should be mounted where it will NOT be exposed to temperatures outside the range of 32°F-120°F (0°C-49°C) or humidity outside the range of 10%-93% at 86°F (30°C) non-condensing.

3.2 Wiring Specifications

Induced noise (transfer of electrical energy from one wire to another) can interfere with telephone communication or cause false alarms. To avoid induced noise, follow these guidelines:

- Isolate input wiring from high current output and power wiring. Do not pull one multi-conductor cable for the entire panel. Instead, separate the wiring as follows:

High voltage	Relay circuits
SLC loops	AC power Terminals
Audio input/output	Phone line circuits
Notification circuits	NAC1 through NAC8
SBUS	

- Do not pull wires from different groups through the same conduit. If you must run them together, do so for as short a distance as possible or use shielded cable. Connect the shield to earth ground at the panel. You must route high and low voltages separately.
- Ground fault and wire to wire short impedance to any terminal is 0Ω.
- Route the wiring around the inside perimeter of the cabinet. It should not cross the circuit board where it could induce noise into the sensitive microelectronics or pick up unwanted RF noise from the high speed circuits. Refer to the FACP manual for wire routing examples.
- High frequency noise, such as that produced by the inductive reactance of a speaker or bell, can also be reduced by running the wire through ferrite shield beads or by wrapping it around a ferrite toroid.



NOTE: All circuits are power limited except the battery and AC cabling. Maintain 0.25 inch spacing between high and low voltage circuits and between power-limited and non-power limited circuits.

3.3 Cabinet Mounting

Refer to the appropriate FACP manual for cabinet mounting instructions and wire routing examples. See Section 1.4 for a list of related documentation.

3.4 Electrical Specifications

Module	Voltage	Standby Current	*Alarm Current (fully loaded system)
ECS-50W 25V	120V 60 Hz	350 mA	1100 mA
ECS-50W 25V	240V 50/60 Hz	200 mA	600 mA
ECS-50W 70V	120V 60 Hz	350 mA	1200 mA
ECS-50W 70V	240V 50/60 Hz	200 mA	600 mA

Table 3.1 ECS-50W AC Current Draw

Module	Voltage	Standby Current	*Alarm Current (fully loaded system)
ECS-125W 25V	120V 60 Hz	300 mA	2200 mA
ECS-125W 25V	240V 50 Hz	250 mA	1250 mA

Table 3.2 ECS-125W AC Current Draw

Module	Voltage	Standby Current	*Alarm Current (fully loaded system)
ECS-DUAL50W 25V	120V 60 Hz	210 mA	2510 mA
ECS-DUAL50W 25V	240V 50/60 Hz	260 mA	1525 mA
ECS-DUAL50W 70V	120V 60 Hz	210 mA	2650 mA
ECS-DUAL50W 70V	240V 50/60 Hz	260 mA	1600 mA

Table 3.3 ECS-DUAL50W AC Current Draw

Section 4: ECS Device Installation

4.1 Connecting AC Power and Batteries

Refer to the *FACP Manual* for proper AC and battery power connections. See Section 1.4 on page 9 for reference documentation.

4.2 Installing the ECS-VCM

The ECS-VCM Voice Control Module is contained within the Farenhyt Series ECS panel enclosure. It provides a supervised microphone for live communication and an interface for the Emergency Communication System. This section provides information on how to install or remove the ECS-VCM to the control cabinet and how to make the proper wiring connections.

4.2.1 ECS-VCM Board Layout

The following is description of the ECS-VCM voice control module components.

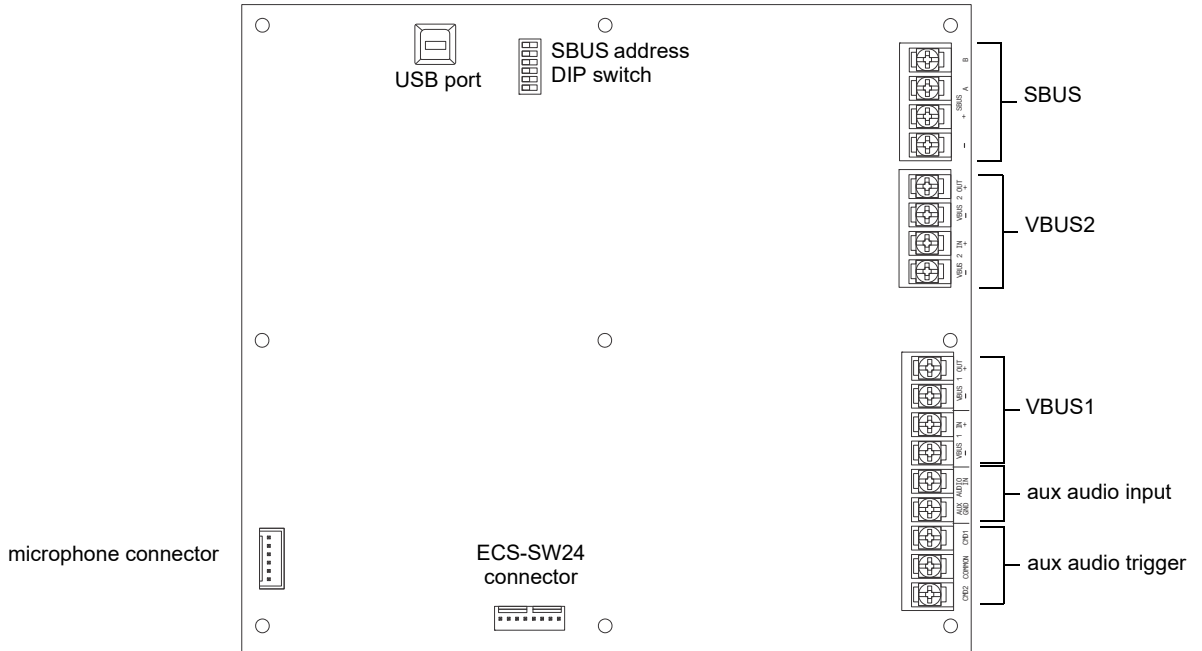

Figure 4.1 Back View of ECS-VCM

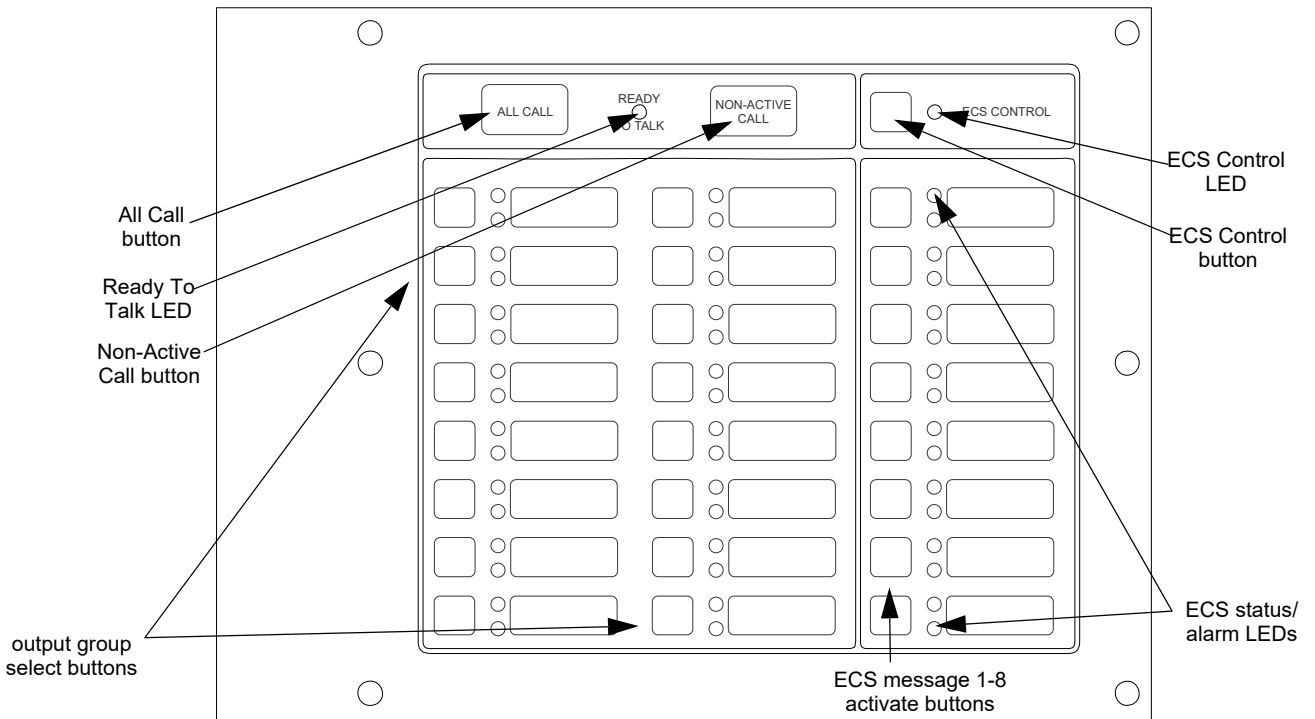

Figure 4.2 Front View of ECS-VCM

4.2.2 Installing the ECS-VCM

1. Open the cabinet door and the dead front panel.
2. Remove AC power and disconnect the backup batteries from the main control panel.
3. Align the ECS-VCM over the mounting studs in the middle section of the dead front panel and secure with the six supplied nuts with lockwashers. Refer to the figure below for mounting locations.

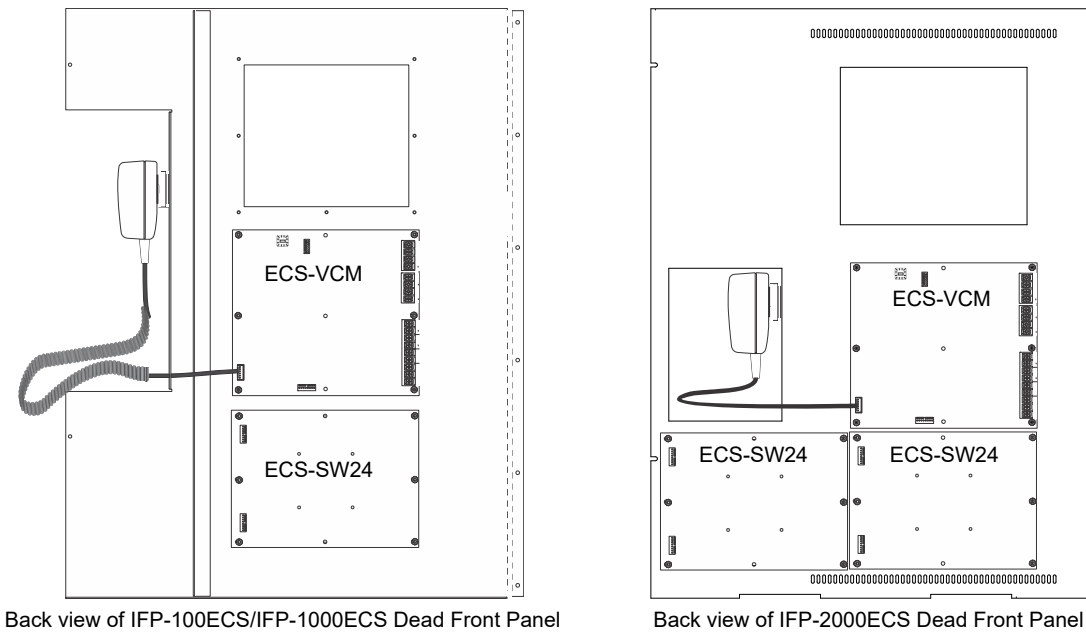

Figure 4.3 ECS-VCM Mounting Locations

4.2.3 Connecting the ECS-VCM to the SBUS

Refer to Figure 4.4 below to properly connect the ECS-VCM to the FACPs SBUS.

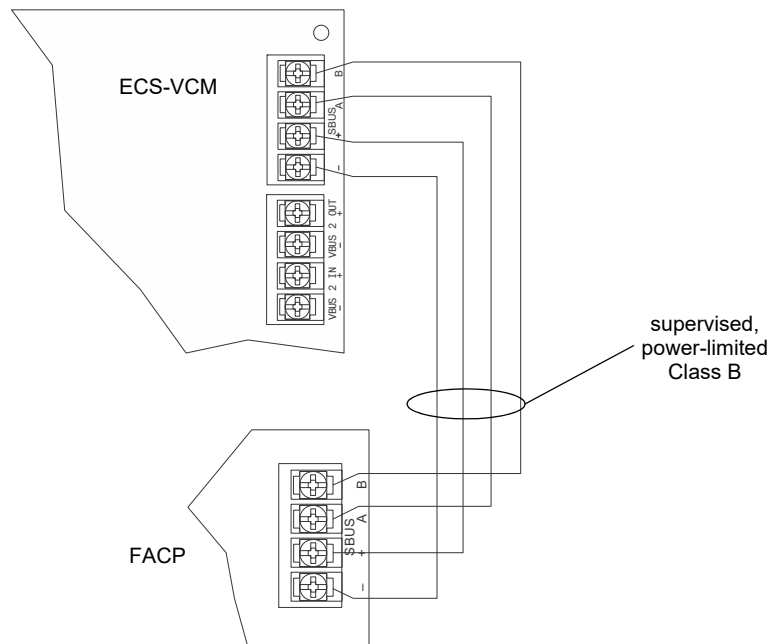

Figure 4.4 ECS-VCM SBUS Connections

See Section 4.11 for instruction on how to set SBUS addressing.

4.2.4 Installing and Connecting the ECS-SW24 to the ECS-VCM

The ECS-SW24 adds 24 switches to the IFP-100ECS, IFP-1000ECS, ECS-LOC, and IFP-2000ECS control panels for a total of 40 (with the 16 non-ECS switches on the ECS-VCM).

Follow these steps to install and connect the ECS-SW24:

1. Open the cabinet door and dead front panel.
2. Remove AC power from the main control panel.
3. Disconnect the backup batteries.
4. Install the ECS-SW24 on the six mounting studs located on the inside of the dead front panel. See Figure 4.3 for mounting locations.
5. Connect one end of the wiring assembly (P/N 130398, supplied) to the ECS-VCM and the other end to the ECS-SW24 as shown in Figure 4.5. If two ECS-SW24 expanders are used (available on IFP-2000ECS and IFP-2100ECS only), connect one ECS-SW24 to the other ECS-SW24 as shown in Figure 4.6.
6. Secure the switch expander(s) to the dead front panel using the supplied six ¼" hex nuts.
7. Restore AC power.
8. Reconnect backup batteries.

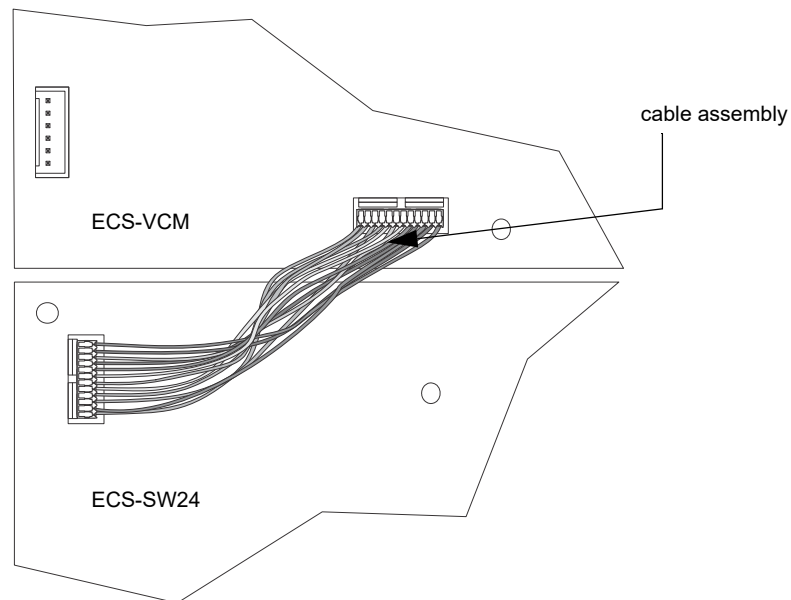

Figure 4.5 Connection for ECS-VCM to ECS-SW24

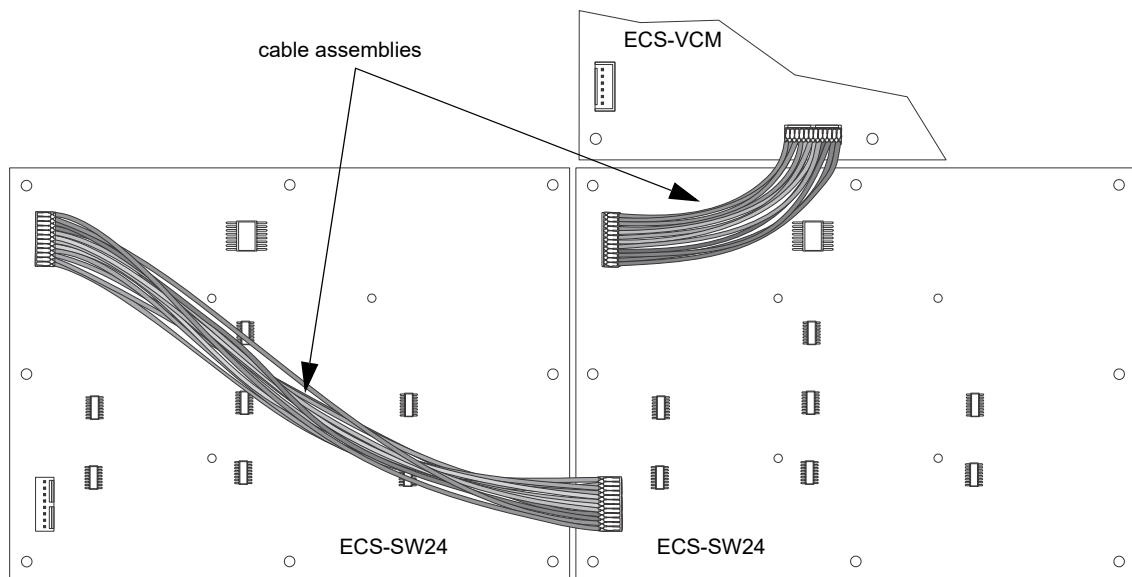

Figure 4.6 Wiring Harness Connection for Multiple ECS-SW24 Modules

4.2.5 Installing the Microphone

To install the microphone follow these steps:

1. Clip the microphone into the microphone clip.

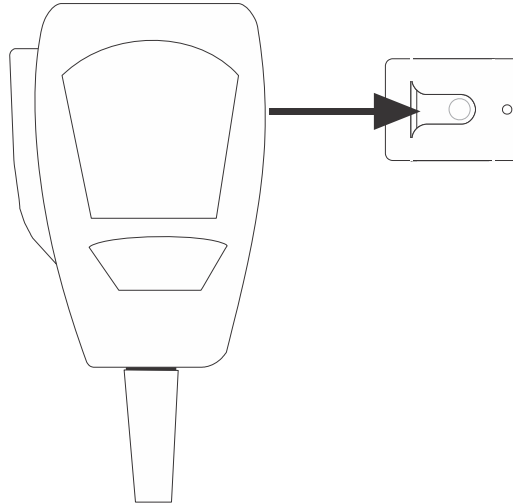

Figure 4.7 Sliding Microphone into Microphone Clip

2. Insert microphone cord through hole at the bottom of the dead front panel.

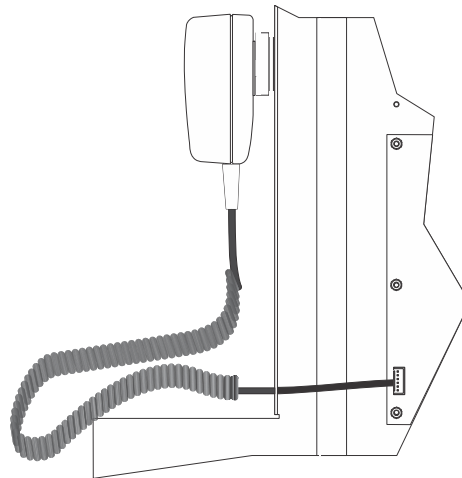

Figure 4.8 Microphone Cord Inserted Through Dead Front Panel Hole

3. Attach strain relief clip to microphone cord. The strain relief clip should have about 2.75" of microphone cord through it.

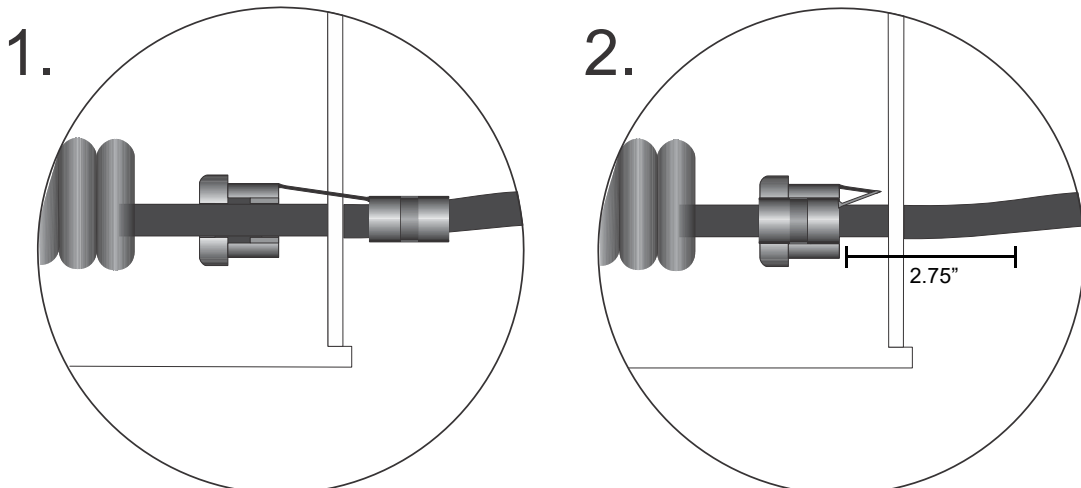

Figure 4.9 Installing Strain Relief Clip

4. Push the strain relief into the hole in the dead front panel.
5. Connect microphone to Connector P2 on ECS-VCM Keypad. Refer to Figure 4.1 for location.

4.3 Installing the ECS-NVCM

This section provides information on the ECS-NVCM, Network Voice Control Module. The ECS-NVCM is compatible with the IFP-2100ECS and ECS-300ECS FACPs.

For more information on how to install or remove the ECS-NVCM Network Voice Control Module, see installation sheet PN LS10169-001SK-E.

4.3.1 ECS-NVCM Board Layout

The following is description of the ECS-NVCM voice control module components.

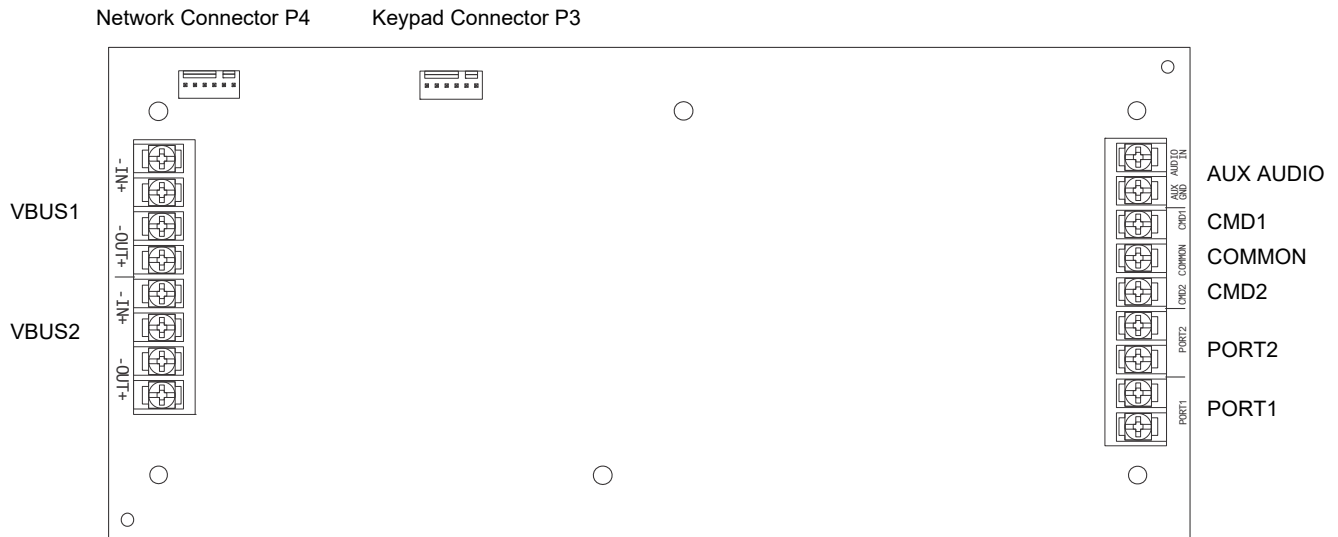

Figure 4.10 Front View of ECS-NVCM

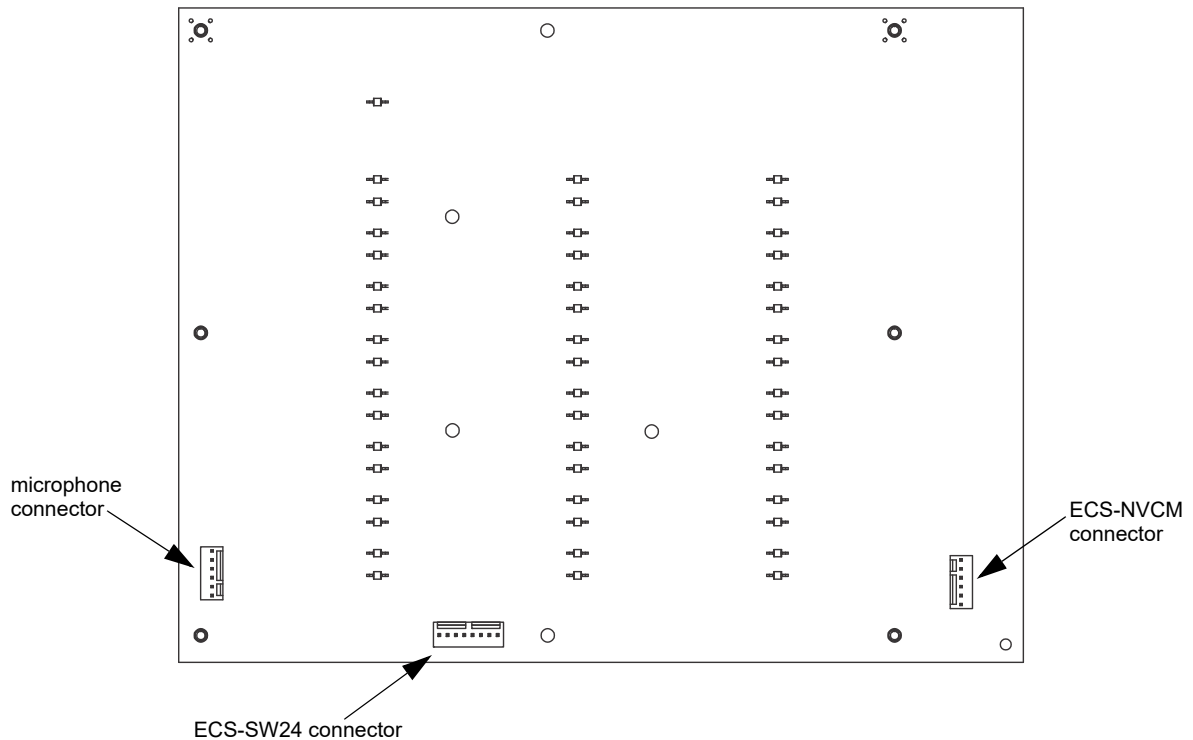

Figure 4.11 Back View of ECS-EMG Keypad

4.3.2 Installing the ECS-NVCM

1. Remove AC power from the FACP.
2. Open the cabinet.
3. Align the ECS-NVCM over the mounting studs below the FACP board and secure with six supplied nuts/lockwashers. Refer to the figures below for mounting locations.

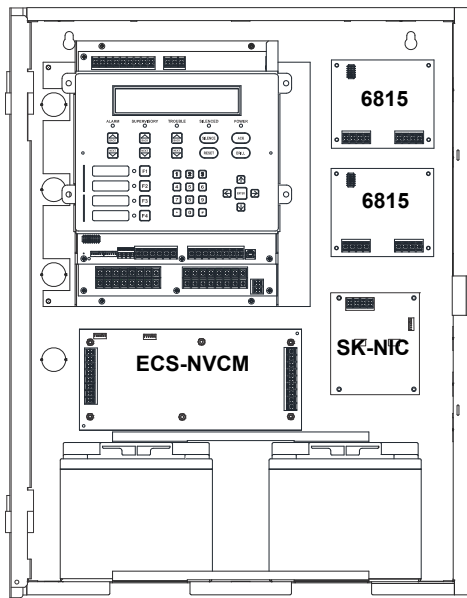

Figure 4.12 ECS-NVCM Mounting Location Inside IFP-2100

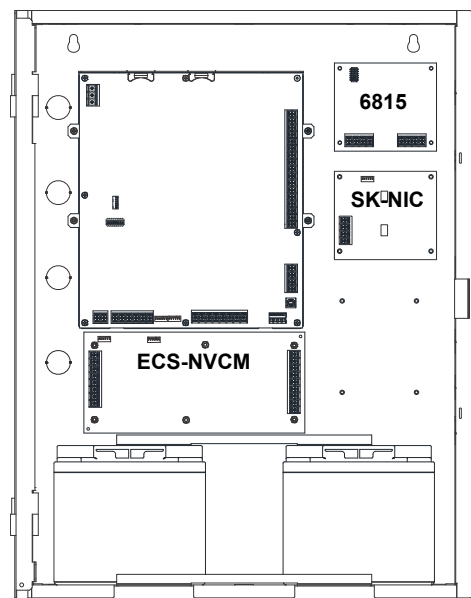

Figure 4.13 ECS-NVCM Mounting Location Inside IFP-300

4.3.3 Installing and Connecting the ECS-EMG to the ECS-SW24

The ECS-SW24 adds 24 switches to the IFP-300ECS and IFP-2100ECS controls for a total of 40, with the 16 non-ECS switches on the ECS-EMG.

Follow these steps to install and connect the ECS-SW24:

1. Open Cabinet door and dead front panel.
2. Remove AC power from the main control panel.
3. Disconnect the backup batteries.
4. Install the ECS-SW24 on the six mounting studs located on the inside of the dead front panel. See Figure 4.14 for IFP-300ECS or Figure 4.15 for IFP-2100ECS.
5. For the IFP-300ECS, connect one end of the wiring harness (P/N 130398 supplied) to the ECS-EMG and the other end to the ECS-SW24 as shown in Figure 4.14.
6. For the IFP-2100ECS, connect one end of the wiring harness (PN 130398 supplied) to the ECS-EMG and the other end to the P4 connector on the ECS-NVCM. If two ECS-SW24 modules are used, connect one ECS-SW24 to the other ECS-SW24. See Figure 4.15.
7. Secure the switch expander(s) to the dead front panel using the supplied six 0.25" hex nuts.
8. Restore AC power.
9. Reconnect backup batteries.

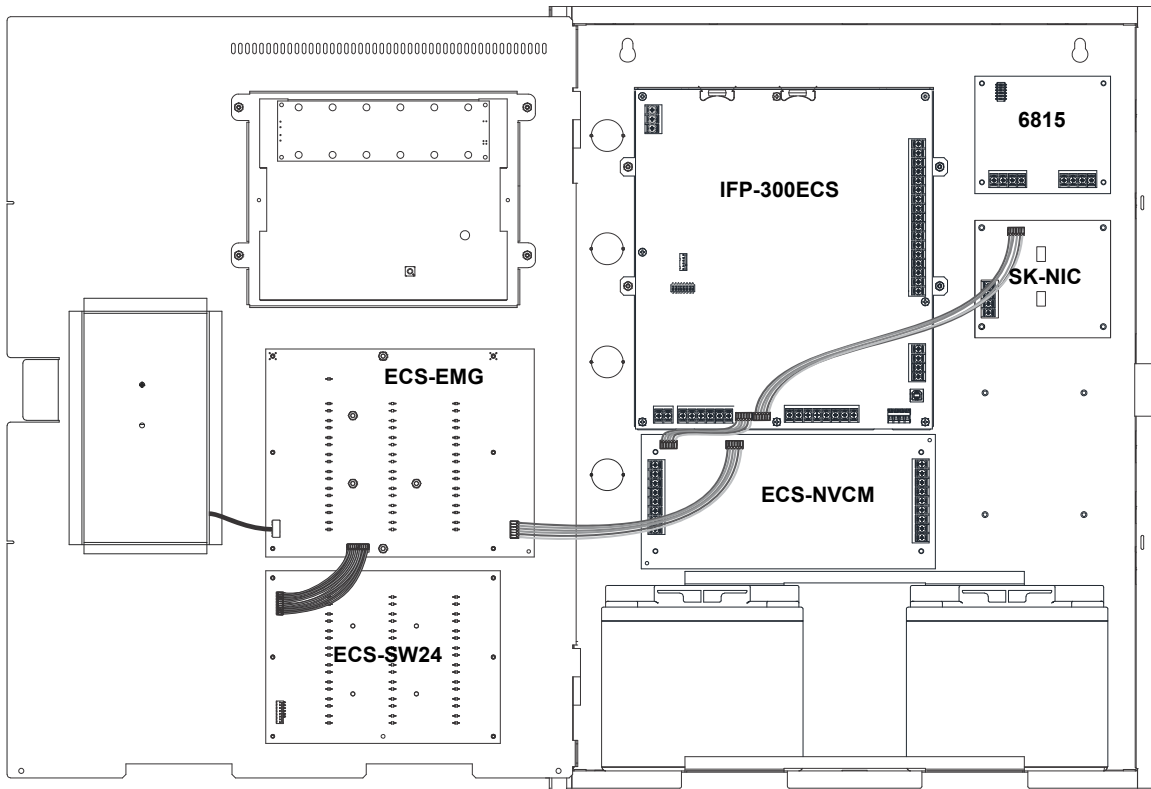

Figure 4.14 Wiring Harness Connections Between the ECS-NVCM/ECS-SW24 to the IFP-300ECS

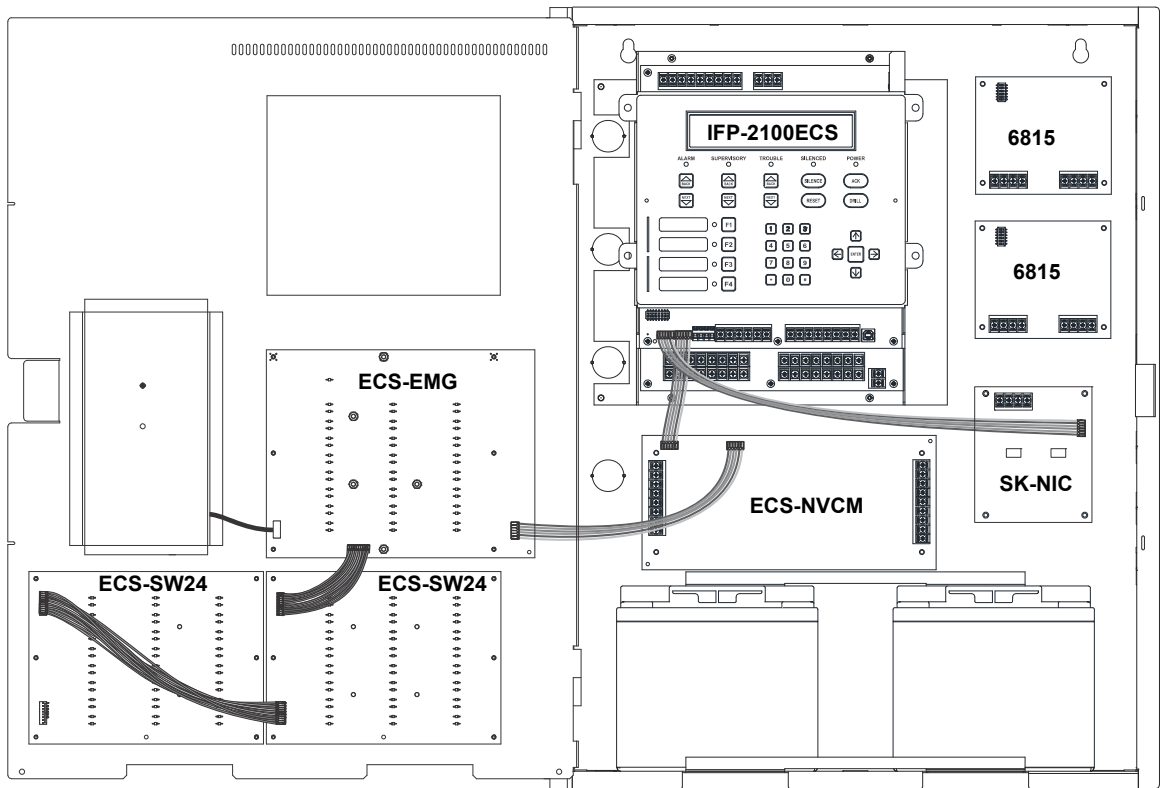
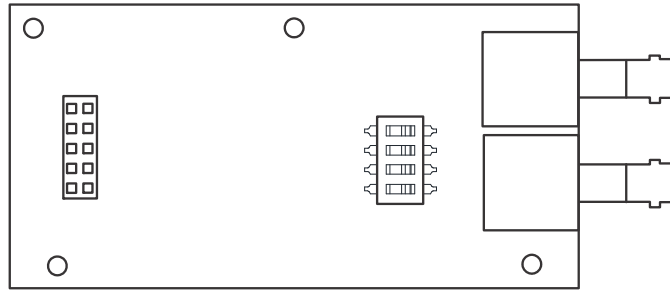

Figure 4.15 Wiring Harness Connections Between the ECS-EMG/ECS-SW24 and the IFP-2100ECS

4.3.4 ECS-NVCM Fiber Modules

The ECS-NVCM supports two types of fiber-option modules to convert wire to fiber. For more information see Installation sheet PN LS10178-001SK-E.

- SK-FML (Fiber-Optic Multi-Mode, Receiver)



- SK-FSL (Fiber-Optic Single-Mode, Transmitter)

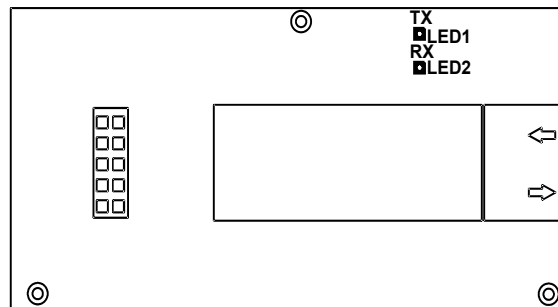

4.3.5 Installing the Microphone

To install the microphone follow these steps:

1. Hang the microphone onto the microphone clip.

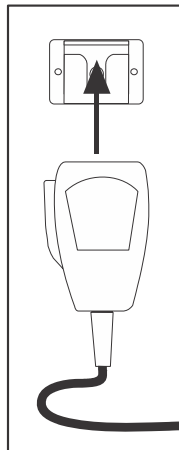

Figure 4.16 Hang Microphone onto Microphone Clip

2. Insert microphone cord through hole at the bottom of the dead front panel.

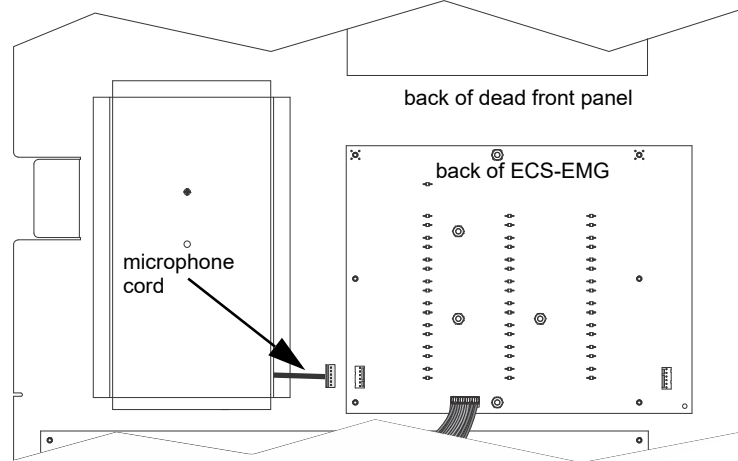

Figure 4.17 Inserting Microphone Cord Through Dead Front Panel Hole

3. Attach strain relief clip to microphone cord. The strain relief clip should have about 2.75" of microphone cord through it.

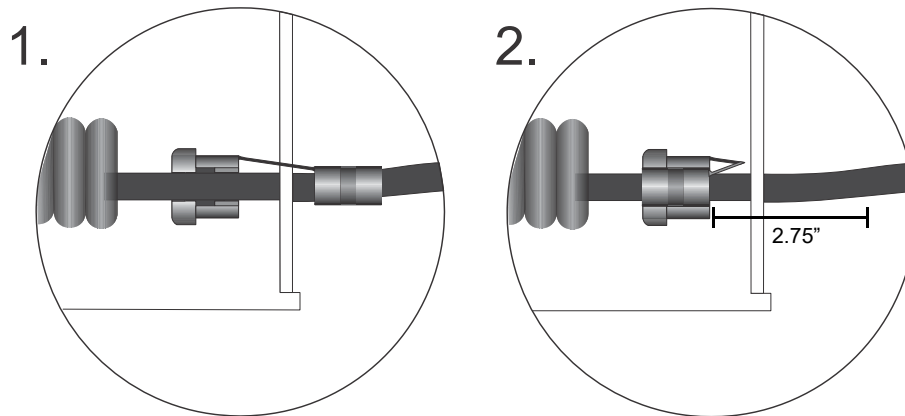

Figure 4.18 Installing Strain Relief Clip

4. Push the strain relief into the hole in the dead front panel.
5. Connect microphone to connector on ECS-EMG.

4.4 Installing the ECS-50W

This section provides information on how to install the ECS-50W for use with the ECS Series products. ECS-50W is also available in a black cabinet as P/N ECS-50WB.

4.4.1 ECS-50W Board Layout

Figure 4.19 shows the location of terminals, DIP switches, and expander connection, used in the installation of the ECS-50W.

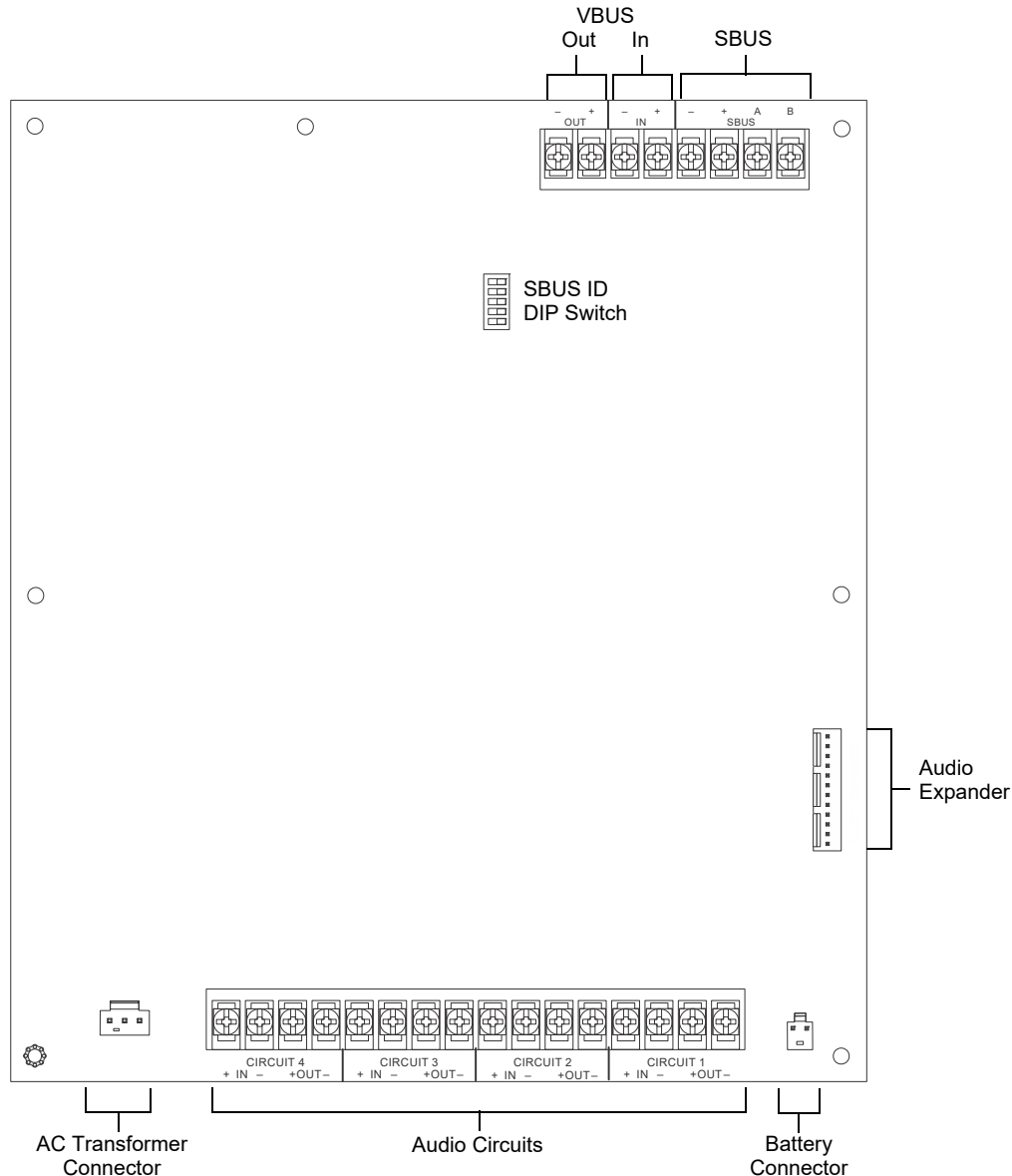

Figure 4.19 Components Layout of ECS-50W

4.4.2 Mounting the ECS-50W

The ECS-50W is equipped with a separate enclosure. Refer to Section when selecting a mounting location for the ECS-50W.

The panel should be accessible to main drop wiring runs. It should be mounted as close to the center of the building as possible and located within a secured area, but should be accessible for testing and service.

Mount the control panel cabinet so it is firmly secured to the wall surface. When mounting on concrete, especially when moisture is expected, attach a piece of $\frac{3}{4}$ " plywood to the concrete surface and then attach the cabinet to the plywood. Also mount any other modules to the plywood.

The cabinet can be surface or flush-mounted. If you will be flush-mounting the cabinet, the hole for the enclosure should be 14.5" W x 24.75" H x 3.44" D (36.8cm W x 62.9cm H x 8.7cm D). Do not flush-mount in a wall designated as a fire break. The outside dimensions of the cabinet are 16" W x 26.5" H x 4.125" D (40.6cm W x 67.3cm H x 10.5cm D).

Follow these steps to properly mount the cabinet.

1. Mark and pre-drill hole in the wall for the center top keyhole mounting bolts using the dimensions below.
2. Install center top fastener in the wall with the screw head protruding.
3. Place backbox over the top screw, level and secure.
4. Mark and drill the lower mounting holes.

5. Install remaining fasteners and tighten.

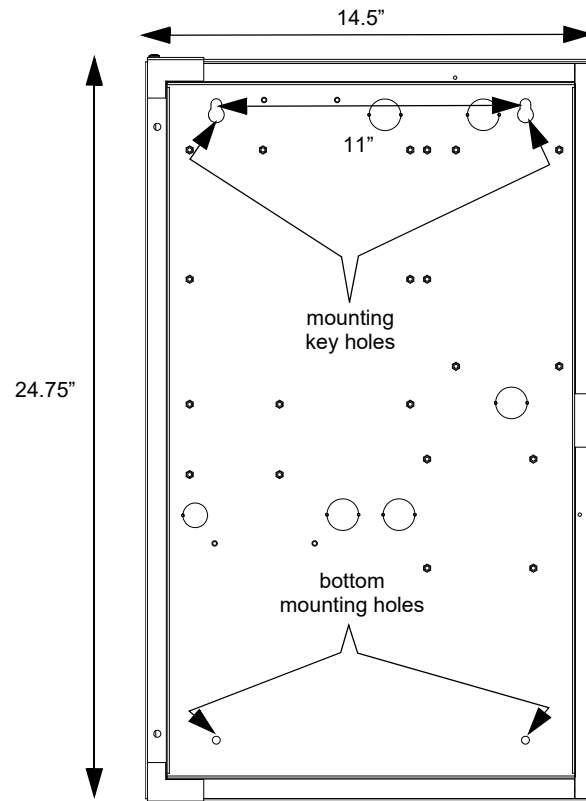

Figure 4.20 Amplifier Cabinet Flush-Mount Dimensions and Mounting Hole Locations

4.4.3 Mounting the ECS-50WBD Board Only



NOTE: Installation and wiring of this device must be done in accordance with NFPA 72 and local ordinance

1. Ensure AC and DC power have been removed from the panel.
2. If this module is a replacement for an existing ECS-50W, remove the seven screws which secure the board to the enclosure.
3. Align the mounting holes over the PEM standoffs in the back of the cabinet.
4. Secure the board to the enclosure with the screws removed in step 2.

- Restore AC power and reconnect the backup batteries.

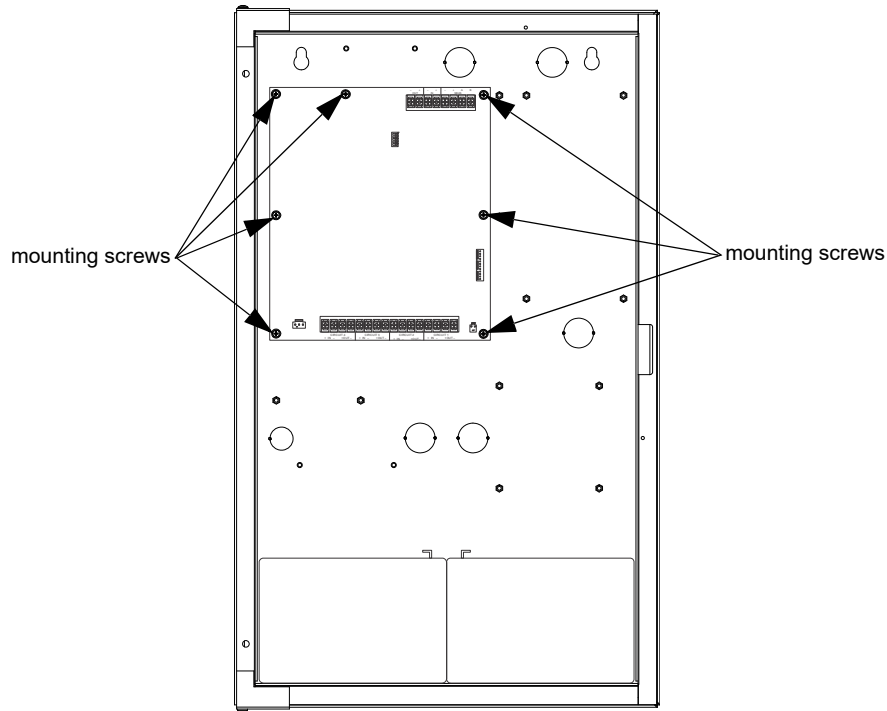

Figure 4.21 ECS-50WBD In Enclosure

4.4.4 Wiring Specifications

All wiring and devices installed in the system must meet the standards described in National Electrical Code (NFPA 70), NFPA Standard 72, and Life Safety Code (NFPA 101).

To avoid induced noise (transfer of electrical energy from one wire to another), keep input wiring isolated from high-current output and power wiring. Avoid pulling one multi-conductor cable for the entire panel.

Separate wiring as follows:

Maintain 0.25" spacing between each of these circuit types; as well as between power-limited and non power-limited circuits.	Input/Output Type:	Wiring
	Non Power-Limited:	AC power, Standby batteries
	Power-Limited:	SBUS, VBUS
	Audio:	Speaker

DO NOT pull wires from different groups through the same conduit.

Twisted, shielded wire is recommended for all audio circuits to provide the maximum protection against EMI and AFI emission and susceptibility.

If using shielded cable, attach the shield to earth ground on the control panel.

For the same reasons, wiring within the cabinet should be routed around the perimeter of the cabinet. It should not cross the printed circuit board where it could induce noise into the sensitive microelectronics or pick up unwanted RF noise from the high speed circuits.

High frequency noise, such as that produced by the inductive 2 reactance of a speaker or bell, can also be reduced by running the wire through ferrite beads or by wrapping it around a ferrite toroid core. Figure 4.22 provides an example.

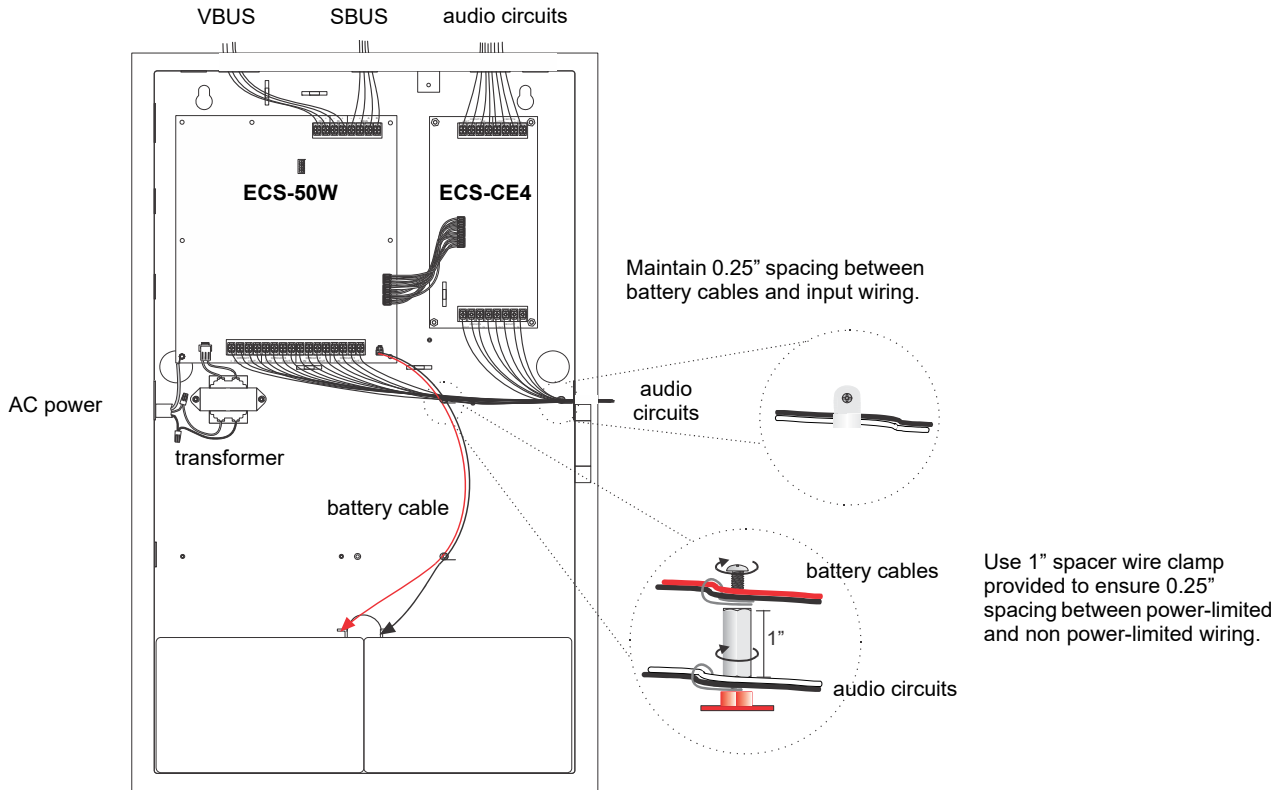

Figure 4.22 Wire Routing Example for the ECS-50W

4.4.5 Speaker Wiring

Each ECS-50W supplies four NAC (Notification Appliance Circuit) for speaker connection. The speaker circuit can be supervised and wired Class B or Class A. The speaker circuit is capable of 50 watts of power at 25 Vrms or 70.7 Vrms.

Wiring Lengths

Number Of Speakers		Total Load		Wire Distance in Feet			
@1/2 W	@1 W	Vrms	Watts	18 AWG	16 AWG	14 AWG	12 AWG
10	5	25Vrms	5W	3900	6200	9860	15680
		70Vrms		25000	39700	63200	100520
20	10	25Vrms	10W	2125	3380	5375	8540
		70Vrms		15200	24150	38400	61100
30	15	25Vrms	15W	1460	2320	3690	5870
		70Vrms		11000	17500	27800	44200
40	20	25Vrms	20W	1100	1750	2780	4420
		70Vrms		8500	13510	21500	34175
52	26	25Vrms	26W	760	1200	1920	3050
		70Vrms		6100	9700	15400	24520
80	40	25Vrms	40W	550	875	1390	2200
		70Vrms		4100	6500	10360	16480
100	50	25Vrms	50W	450	715	1130	1800
		70Vrms		3500	5560	8850	14070



NOTE: The above table assumes a uniform distribution of the speakers, and that a max of 20% voltage drop on the last speaker is allowed

Class B Speaker Configuration

Figure 4.23 illustrates how to wire speakers to the control panel using Class B supervision.

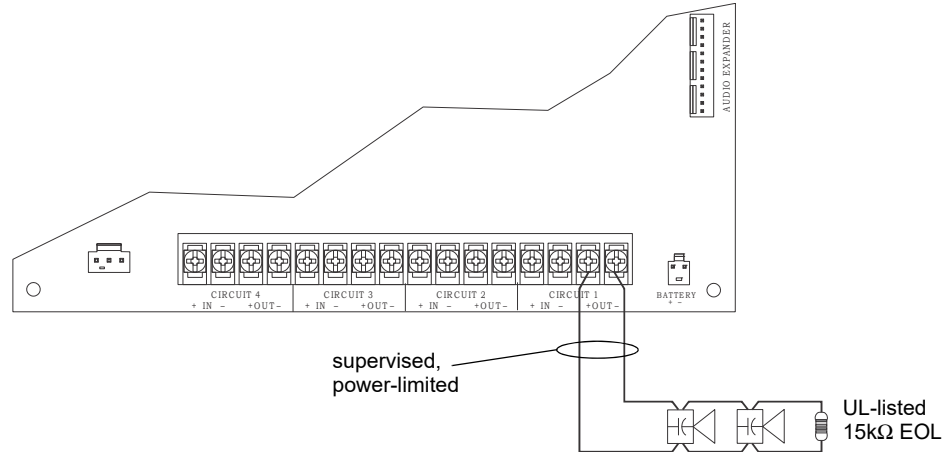

Figure 4.23 Class B Speaker Configuration

Class A Speaker Configuration

Figure 4.24 illustrates how to wire speakers to the control panel using Class A wiring.

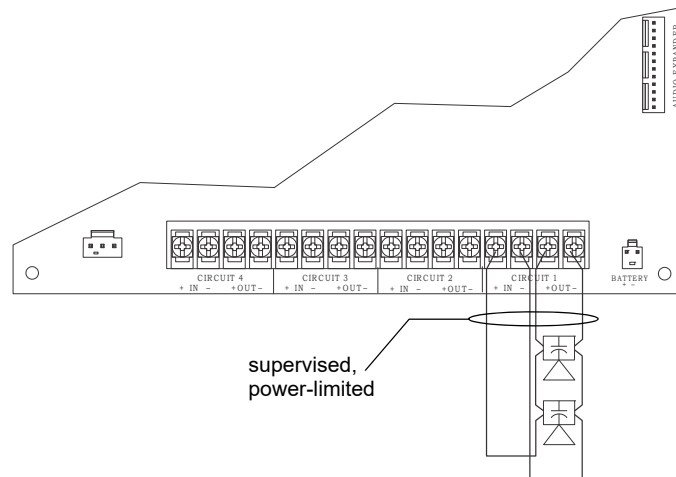

Figure 4.24 Class A Speaker Configuration

4.4.6 VBUS Wiring

The VBUS is an analog voice bus that carries the recorded voice messages from the ECS-VCM or ECS-NVCM to the ECS-50W, or the voice messages generated from a system microphone to the ECS-50W. The maximum resistance on the VBUS is 20Ω.

Connect the VBUS from the ECS-VCM to the ECS-50W amplifiers as shown in Figure 4.25 or ECS-NVCM as shown in Figure 4.26.

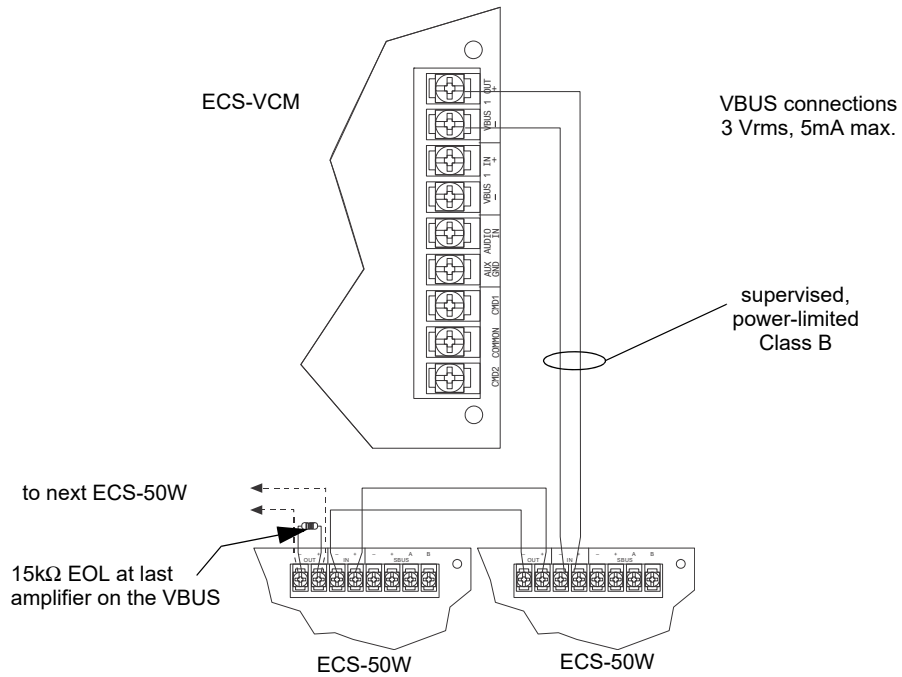

Figure 4.25 VBUS Wiring for the ECS-VCM to the ECS-50W

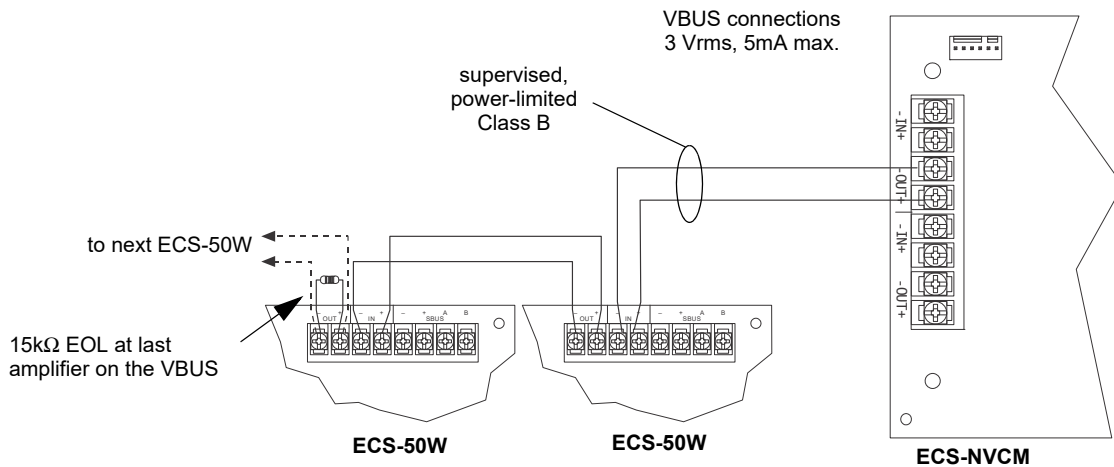

Figure 4.26 VBUS Wiring for the ECS-NVCM to the ECS-50W

4.4.7 SBUS Wiring

This section contains information on how to connect ECS-50W amplifiers (up to 8 for IFP-100ECS, IFP-300ECS, or IFP-1000ECS or up to 16 for IFP-2000ECS or IFP-2100ECS) onto the main control SBUS. Refer to the FACP manual for SBUS specifications. Wire the SBUS as shown in Figure 4.27.

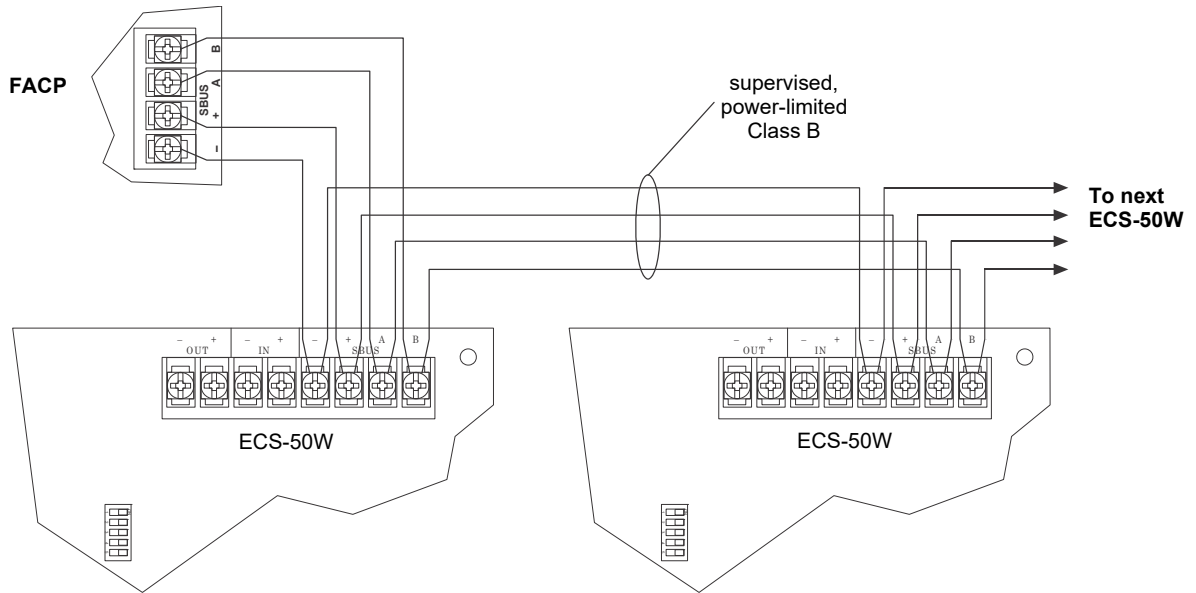

Figure 4.27 Connecting ECS-50W Amplifiers to the SBUS

See Section 4.11 for information on setting SBUS addresses.

4.4.8 Connecting AC Power

The AC inputs are rated as 120 VAC, 60 Hz or 240 VAC, 50/60 Hz (transformer P/N 115061 or 29201).

To install the AC transformer into the ECS-50W cabinet follow these steps:

1. Open the cabinet door.
2. To access cabinet interior, open the dead-front panel by removing the upper screw and the mid-door retaining screw.
3. Mount the transformer onto the threaded cabinet transformer mounting studs using the supplied locking hex nuts as shown in Figure 4.28.

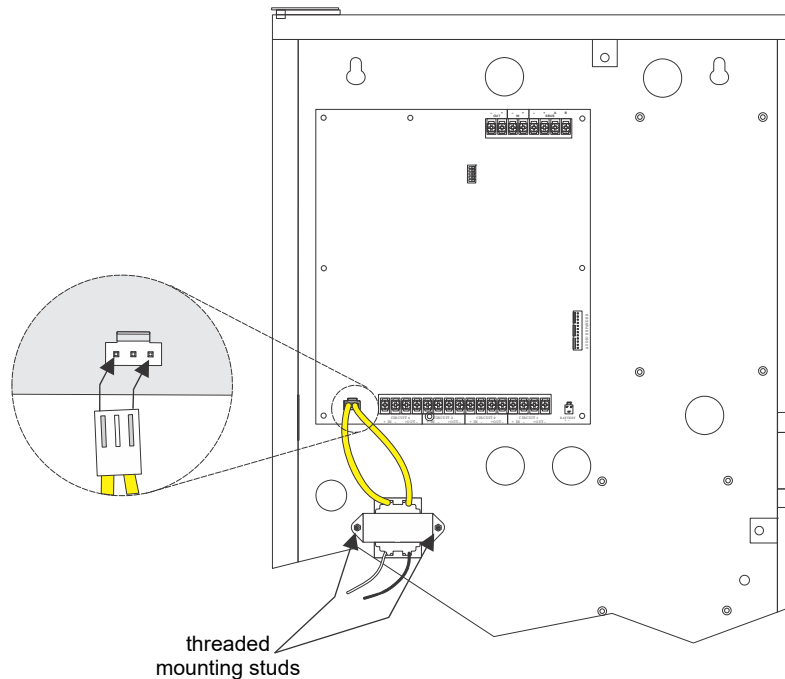

Figure 4.28 Transformer Mounting

4. Connect AC power to the transformer as shown in Figure 4.29.

5. Plug the transformer output to the AC connector on the control panel as shown below.

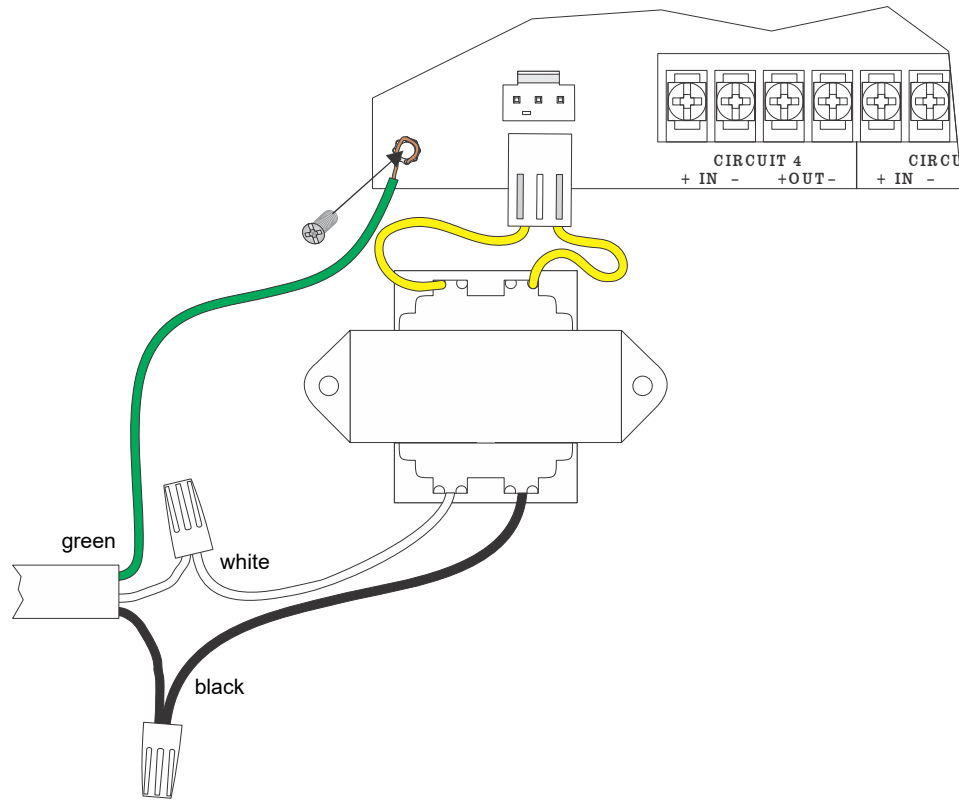

Figure 4.29 AC Connections

4.4.9 Backup Battery for ECS-50W

The following steps explain how to connect the batteries (refer to Figure 4.30):

1. Connect the black wire of the battery harness to the (-) side of the battery #2.
2. Connect the jumper wire provided from the positive (+) side of battery #2 to the negative side of battery #1.
3. Connect the red wire from the battery harness to the positive (+) side of battery #1.

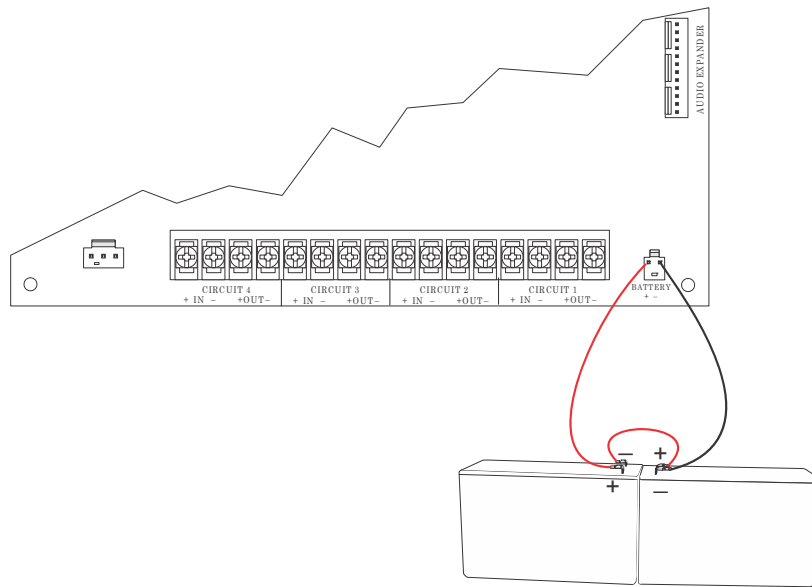

Figure 4.30 Battery Connections to the ECS-50W

4.4.10 Calculating Current Draw and Standby Battery

This section helps you determine the current draw and standby battery needs for your installation (18 ampere hours max. will fit in cabinet). These capacities have a built-in 20% derating factor. Complete the remaining instructions in Table 4.1.

Batteries larger than 18 AH will not fit in the main control cabinet, and must be housed in the RBB Accessory Battery Cabinet. The system supports a maximum of 33 AH batteries.

Device	No. of Devices	Current Per Device	Standby Current	Alarm Current
ECS-50W 25V	1	Standby: 85 mA	85 mA	
		Alarm: 525 mA		525 mA
ECS-50W 70.7V	1	Standby: 100 mA	100 mA	
		Alarm: 580 mA		580 mA
ECS-CE4	0 or 1	Standby: 20 mA	20mA	
		Alarm (All Channels): 180 mA		180 mA
A Current Subtotals:			mA	mA
Notification Devices		Refer to device manual for number of devices and current ratings.		
B Current Subtotals:			mA	mA
C Total current rating of all devices in system (Line B) X 0.001			A	A
D Number of standby hours (24 or 60 for NFPA 72)			H	
E Multiply line C (standby current) and D: Total standby AH			AH	
F Alarm sounding period in hours (For example, 5 minutes = 0.0833 hours):				H
G Multiply line C (alarm current) and F: Total alarm AH				AH
H Add lines E and G (AH = Ampere Hours): Total AH required			AH	

Table 4.1 Current Draw ECS-50W and ECS-CE4

4.5 Installing the ECS-INT50W

This section provides information on how to install the ECS-INT50W for use with the ECS Series products. The ECS-INT50W Internal Amplifier can fit inside the IFP-300ECS or IFP-2000ECS cabinets. It can also be adapted to fit into the IFP-2100ECS cabinet with the ECS-AMPMT mounting kit (sold separately). It is used to amplify the audio message for distribution throughout the facility for the Emergency Communication System.

4.5.1 Board Layout & Mounting

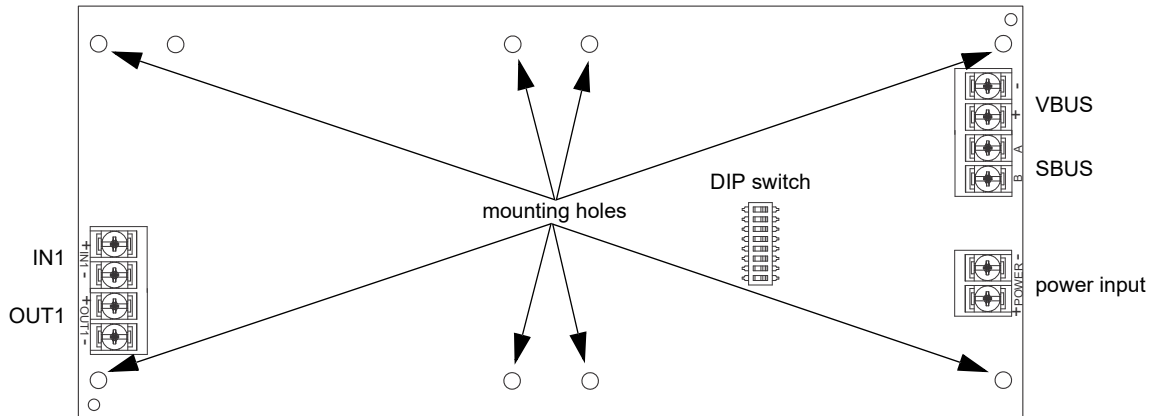

Figure 4.31 ECS-INT50W Board Layout

Mounting the ECS-INT50W

1. Remove AC power and disconnect the backup batteries from the main control panel.
2. To mount the ECS-INT50W inside the FACP cabinet below the main board, align the board with the mounting holes and secure the board to the enclosure with the eight supplied screws.

When mounting the ECS-INT50W in the ECS cabinet that contains an ECS-NVCM, it is necessary to mount the ECS-INT50W on the right side of the control board. To do this, you will need the ECS-AMPMT mounting kit (ordered separately).

1. Mount the ECS-AMPMT plate into the cabinet using the six supplied screws. Orient with “Top” side up.

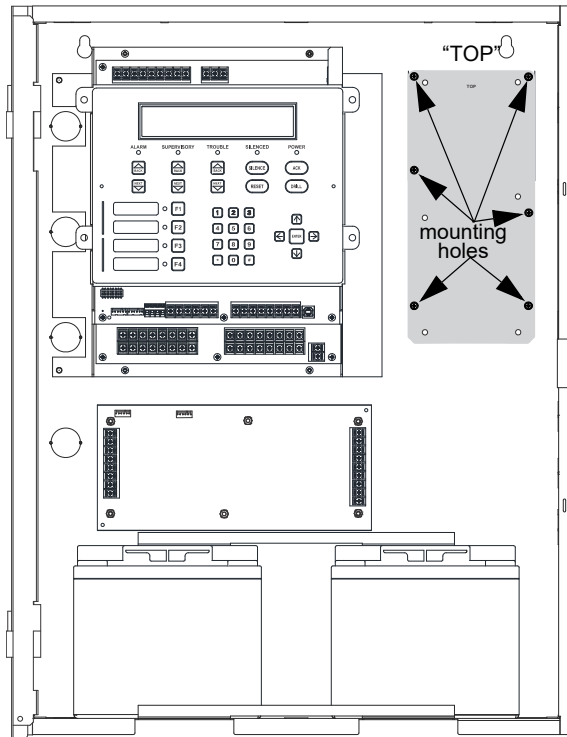

Figure 4.32 ECS-AMPMT installed in Cabinet

2. Secure the ECS-INT50W onto the six PEM studs on the mounting plate with six supplied screws. Ensure the side with only one terminal block is at the top of the ECS-AMPMT. See the figure below.

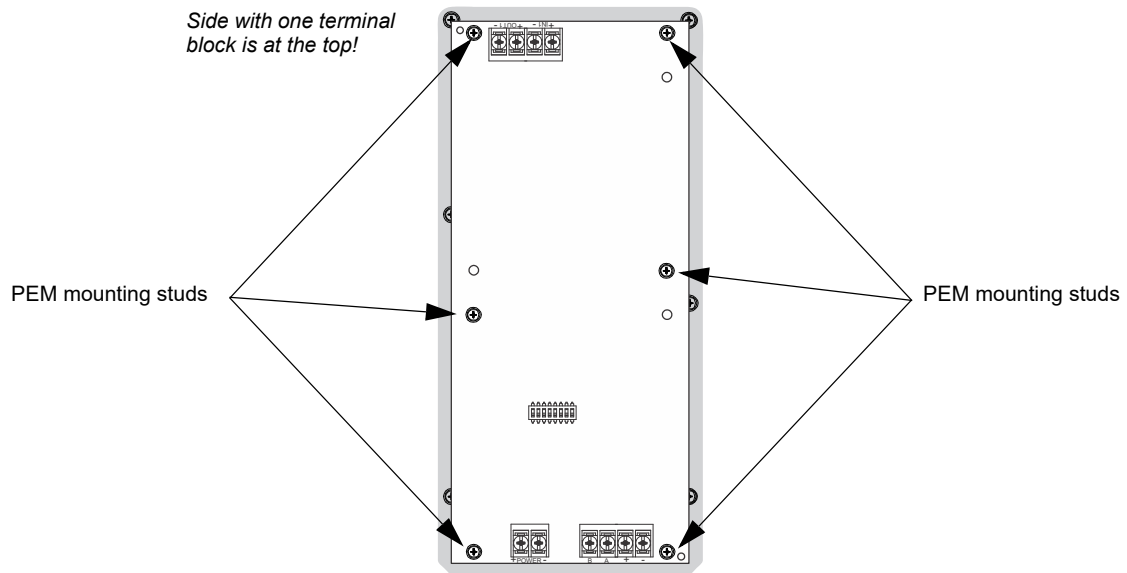

Figure 4.33 ECS-INT50W Installed Using the ECS-AMPMT

4.5.2 Wiring to an FACP

See Figure 4.34 to properly wire the SBUS and power of the ECS-INT50W to the FACP.

The internal amplifier must be powered by either a NAC programmed as constant auxiliary power or by an auxiliary power supply UL-listed for fire protective signaling. Refer to the FACP installation manual for more information.

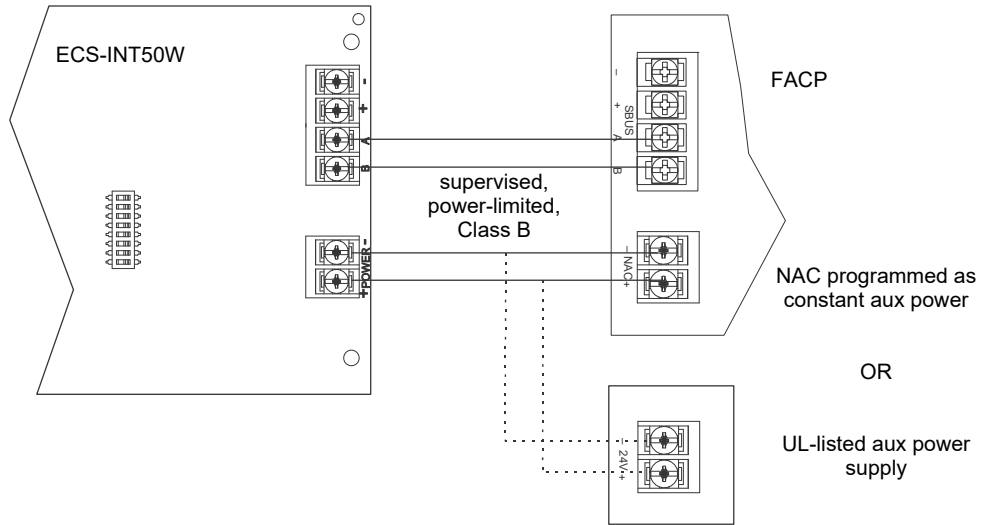

Figure 4.34 Wiring the ECS-INT50W to the FACP

4.5.3 VBUS Wiring

The VBUS is an analog voice bus that carries the recorded voice messages from the ECS-VCM or ECS-NVCM to the ECS-INT50W amplifiers, or the voice messages generated from a system microphone to the ECS-INT50W.

The maximum resistance on the VBUS is 20Ω.

Connect the VBUS from the ECS-VCN to the ECS-INT50W amplifiers as shown in Figure 4.35 or the ECS-NVCM to the ECS-INT50W as shown in Figure 4.36.

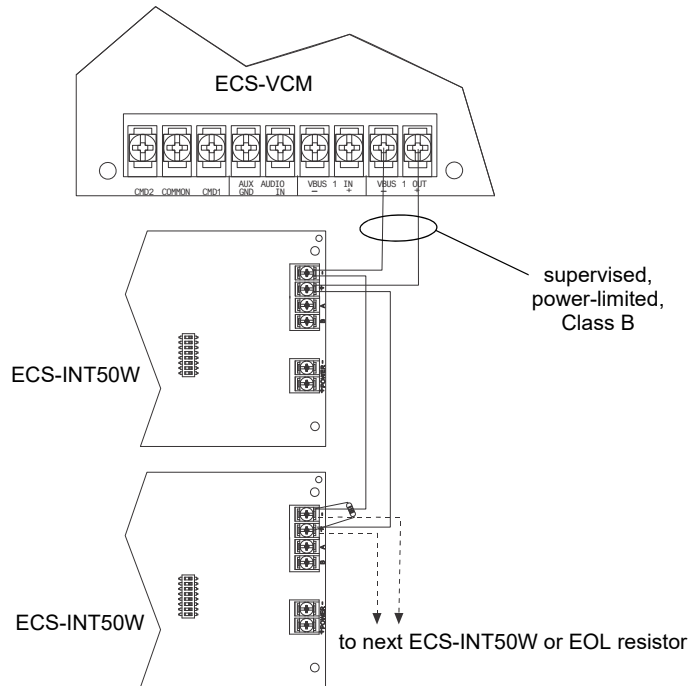

Figure 4.35 VBUS Wiring for ECS-VCN to ECS-INT50W

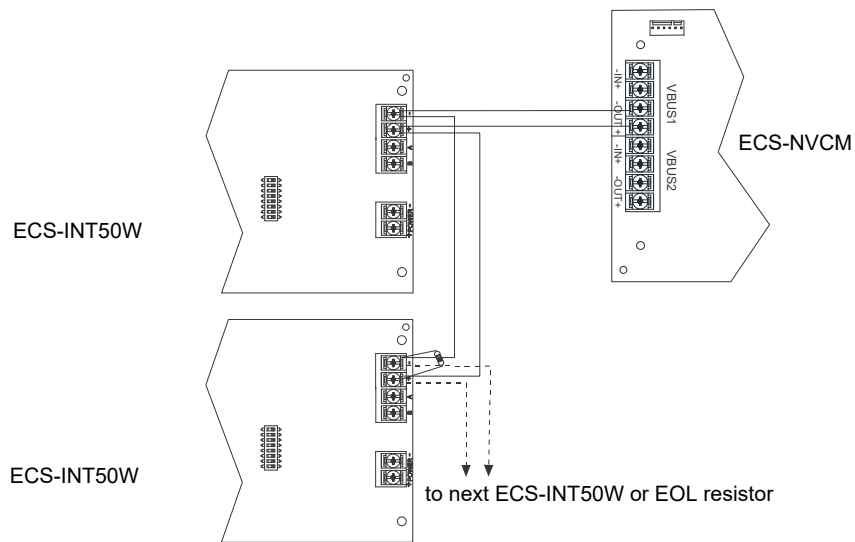

Figure 4.36 VBUS Wiring for ECS-NVCM to ECS-INT50W

4.5.4 Setting the Device Address

Use the onboard DIP switches to select an ID number for the ECS-INT50W. Refer to Figure 4.77 on page 61 to set the DIP switches for the desired ID number.

Once the ID number is set, add the ECS-INT50W to the system through programming.



NOTE: The ECS-INT50W is powered by a NAC on the FACP or by an auxiliary power supply. It will not be found using JumpStart AutoProgramming.

4.5.5 Speaker Wiring

Each ECS-INT50W supplies one circuit for speaker connection. The speaker circuit can be supervised and wired Class B or Class A. The speaker circuit is capable of 50 watts of power at 25 Vrms or 70.7 Vrms. See Section 4.4.5 for wire lengths.

4.5.6 Calculating Current Draw and Standby Battery

This section helps to determine the current draw and standby battery needs for your installation. These capacities have a built-in 20% derating factor. Complete the remaining instructions in Table 4.2.

Batteries larger than 18 AH will not fit in the main control cabinet, and must be housed in the RBB Accessory Battery Cabinet. The system supports a maximum of 33 AH batteries.

	Device	No. of Devices	Current Per Device	Standby Current	Alarm Current
	ECS-INT50W 25V	1	Standby: 52 mA	52mA	
			Alarm: 275 mA		275mA
	ECS-INT50W 70V	1	Standby: 52 mA	52mA	
			Alarm: 310 mA		310mA
A	Current Subtotals:			mA	mA
	Notification Devices	Refer to device manual for number of devices and current ratings.			
B	Current Subtotals:			mA	mA
C	Total current rating of all devices in system (Line B) X 0.001			A	A
D	Number of standby hours (24 or 60 for NFPA 72)			H	
E	Multiply line C (standby current) and D: Total standby AH			AH	
F	Alarm sounding period in hours (For example, 5 minutes = 0.0833 hours):				H
G	Multiply line C (alarm current) and F: Total alarm AH				AH
H	Add lines E and G (AH = Ampere Hours): Total AH required			AH	

Table 4.2 Current Draw Calculations

4.6 Installing the ECS-125W

This section provides information on how to install the ECS-125W for use with ECS series products.

4.6.1 ECS-125W Board Layout

Figure 4.37 shows the location of terminals, DIP switches, and expander connections used in the installation of the ECS-125W.

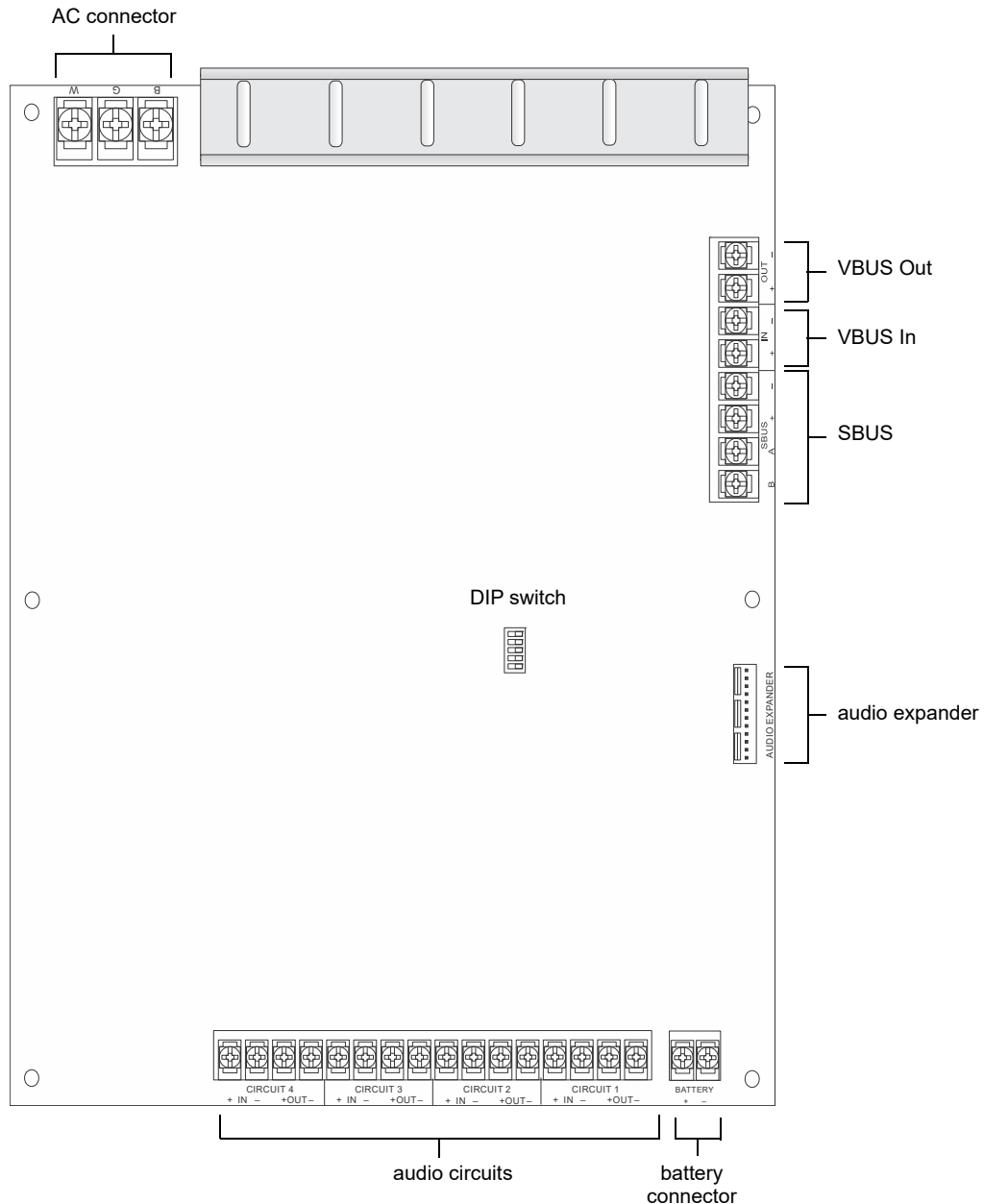

Figure 4.37 ECS-125W Board Layout

4.6.2 Mounting the ECS-125W

The ECS-125W is equipped with a separate enclosure. Refer to Section 3.1 when selecting a mounting location for the ECS-125W.

The panel should be accessible to main drop wiring runs. It should be mounted as close to the center of the building as possible and located within a secured area, but should be accessible for testing and service.

Mount the control panel cabinet so it is firmly secured to the wall surface. When mounting on concrete, especially when moisture is expected, attach a piece of 3/4-inch plywood to the concrete surface and then attach the cabinet to the plywood. Also, mount any other modules to the plywood.

The cabinet can be surface or flush-mounted. For flush-mounting the cabinet, the hole for the enclosure should be 14.5" W x 24.75" H x 3.44" D (36.8cm W x 62.9cm H x 8.7cm D). Do not flush-mount in a wall designated as a fire break. The outside dimensions of the cabinet are 16" W x 26.25" H x 4.125" D (40.6cm W x 66.7cm H x 10.5cm D).

Follow these steps to properly mount the cabinet.

1. Mark and pre-drill hole in the wall for the center top keyhole mounting bolts using the dimensions below.

2. Install center top fastener in the wall with the screw head protruding.
3. Place backbox over the top screw, level and secure.
4. Mark and drill the lower mounting holes.
5. Install remaining fasteners and tighten.

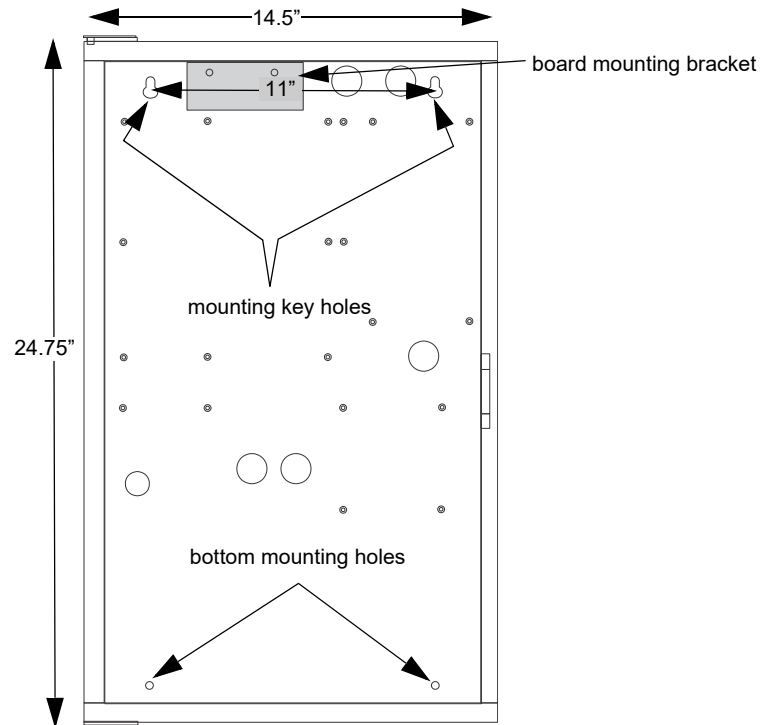

Figure 4.38 Cabinet Flush-Mount Dimensions and Mounting Hole Locations

4.6.3 Mounting the ECS-125WBD Board Only



NOTE: Installation and wiring of this device must be done in accordance with NFPA 72 and local ordinance

1. Ensure AC and DC power have been removed from the panel.
2. If this module is a replacement for an existing ECS-125W, remove the screws which secure the board to the enclosure.

- Secure the supplied “L-shaped” bracket to the top mounting bracket on the ECS-125WBD with the two mounting screws.

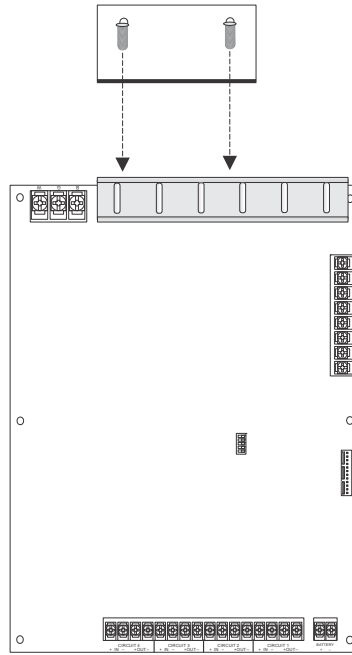

Figure 4.39 ECS-125WBD Mounting Bracket

- Align the mounting holes on the bracket with the enclosure.
- Secure the board to the enclosure.
- Restore AC power and reconnect the backup batteries.

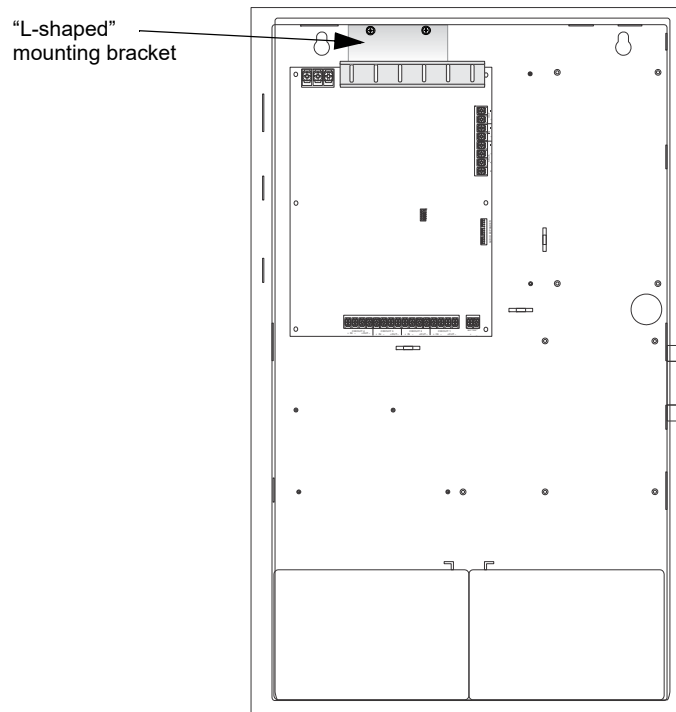

Figure 4.40 ECS-125WBD In Enclosure

4.6.4 Wiring Specifications

All wiring and devices installed in the system must meet the standards described in National Electrical Code (NFPA 70), NFPA Standard 72, and Life Safety Code (NFPA 101).

To avoid induced noise (transfer of electrical energy from one wire to another), keep input wiring isolated from high-current output and power wiring. Avoid pulling one multi-conductor cable for the entire panel.

Separate wiring as follows:

Maintain 0.25" spacing between each of these circuit types; as well as between power-limited and non power-limited circuits.	Input/Output Type:	Wiring
	Non Power-Limited:	AC power, Standby batteries
	Power-Limited:	SBUS, VBUS
	Audio:	Speaker

DO NOT pull wires from different groups through the same conduit.

Twisted, shielded wire is recommended for all audio circuits to provide the maximum protection against EMI and AFI emission and susceptibility.

If using shielded cable, attach the shield to earth ground on the control panel.

For the same reasons, wiring within the cabinet should be routed around the perimeter of the cabinet. It should not cross the printed circuit board where it could induce noise into the sensitive microelectronics or pick up unwanted RF noise from the high speed circuits.

High frequency noise, such as that produced by the inductive reactance of a speaker or bell, can also be reduced by running the wire through ferrite beads or by wrapping it around a ferrite toroid core. Figure 4.41 provides an example.

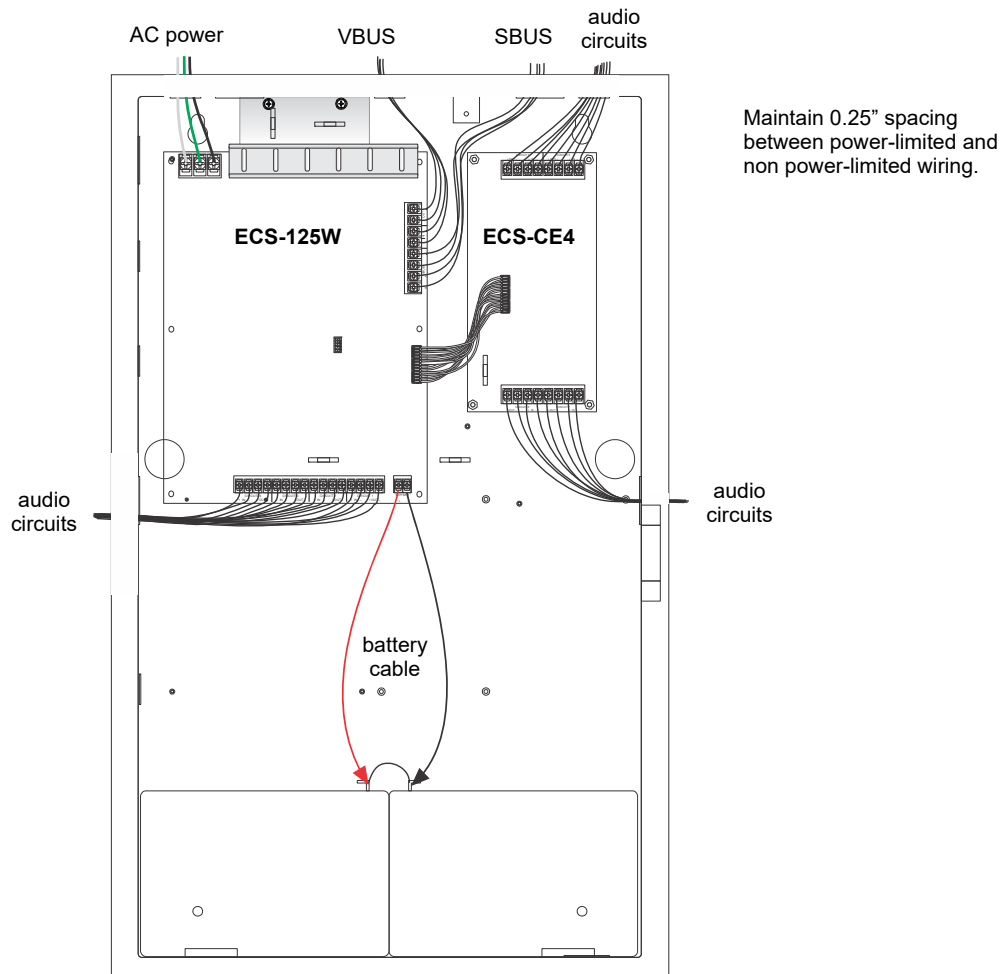

Figure 4.41 Wire Routing Example for the ECS-125W

4.6.5 Speaker Wiring

Each ECS-125W supplies four NACs (Notification Appliance Circuits) for speaker connection. The speaker circuit can be supervised and wired Class B or Class A. Speaker circuit 1 is capable of 100 watts of power at 25 Vrms. Speaker circuit 2-4 are capable of 50 watts (each) at 25 Vrms.

Wiring Lengths

Number Of Speakers		Total Load		Wire Distance in Feet			
@1/2 W	@1 W	Vrms	Watts	18 AWG	16 AWG	14 AWG	12 AWG
10	5	25Vrms	5W	3900	6200	9860	15680
20	10	25Vrms	10W	2125	3380	5375	8540
30	15	25Vrms	15W	1460	2320	3690	5870
40	20	25Vrms	20W	1100	1750	2780	4420
52	26	25Vrms	26W	760	1200	1920	3050
80	40	25Vrms	40W	550	875	1390	2200
100	50	25Vrms	50W	450	715	1130	1800
150	75	25Vrms	75W	300	476	753	1200
200	100	25Vrms	100W	225	357	565	900
250	125	25Vrms	125W	180	285	452	720

Table 4.3 ECS-125W Wire Lengths



NOTE: The above table assumes a uniform distribution of the speakers, and that a max of 20% voltage drop on the last speaker is allowed.

Class B

Figure 4.42 illustrates how to wire speakers to the control panel using Class B supervision.

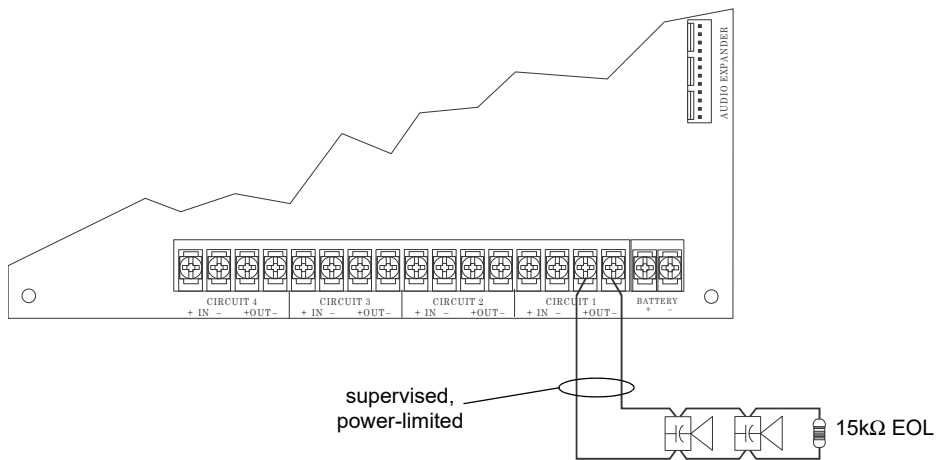

Figure 4.42 Class B Speaker Configuration

Class A

Figure 4.43 illustrates how to wire speakers to the control panel using Class A wiring.

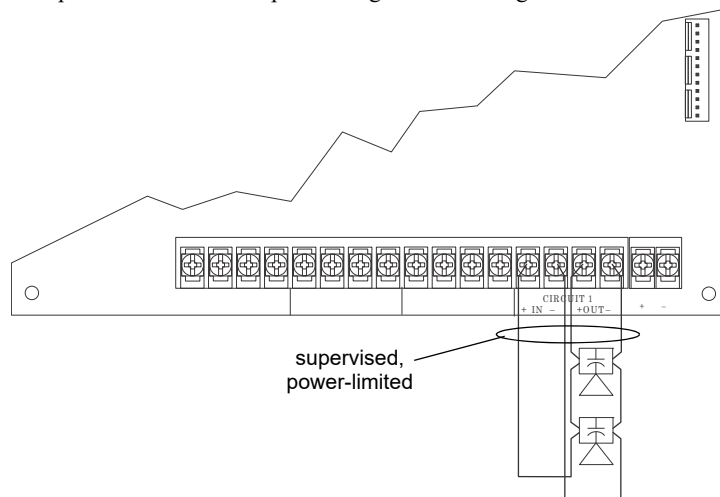

Figure 4.43 Class A Speaker Configuration

4.6.6 VBUS Wiring

The VBUS is an analog voice bus that carries the recorded voice messages from the ECS-VCM or ECS-NVCM to the ECS-125W or the voice messages generated from a system microphone to the ECS-125W. The maximum resistance on the VBUS is 20Ω.

Connect the VBUS from the ECS-VCM to the ECS-125W amplifiers as shown in Figure 4.44 or from the ECS-NVCM to the ECS-125W as shown in Figure 4.45.

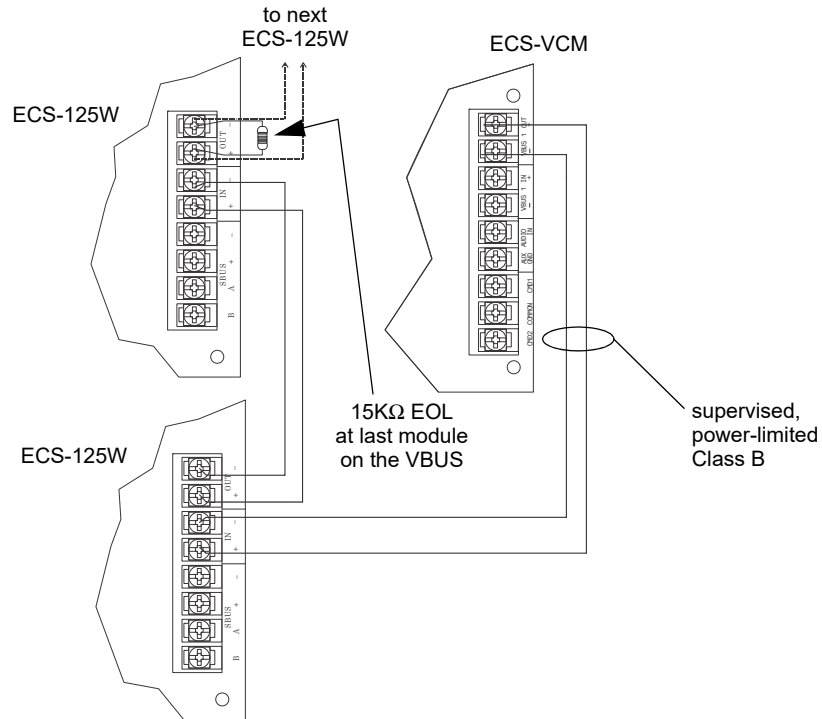

Figure 4.44 VBUS Wiring for ECS-VCM

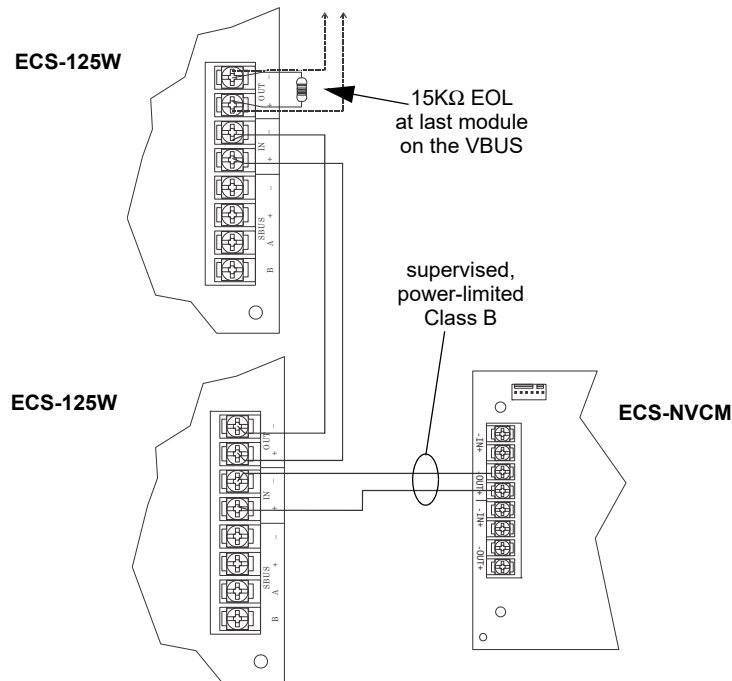

Figure 4.45 VBUS Wiring for ECS-NVCM

4.6.7 SBUS Wiring

This section contains information on how to connect ECS-125W amplifiers (up to 8 for IFP-100ECS, IFP-300ECS, or IFP-1000ECS; up to 16 for IFP-2000ECS or IFP-2100ECS) onto the main control SBUS. Refer to Section 4 of the FACP Installation manual for SBUS specifications. Wire the SBUS as shown in Figure 4.46 using the ECS-VCM. Wire the SBUS as shown in Figure 4.47 using the ECS-NVCM.

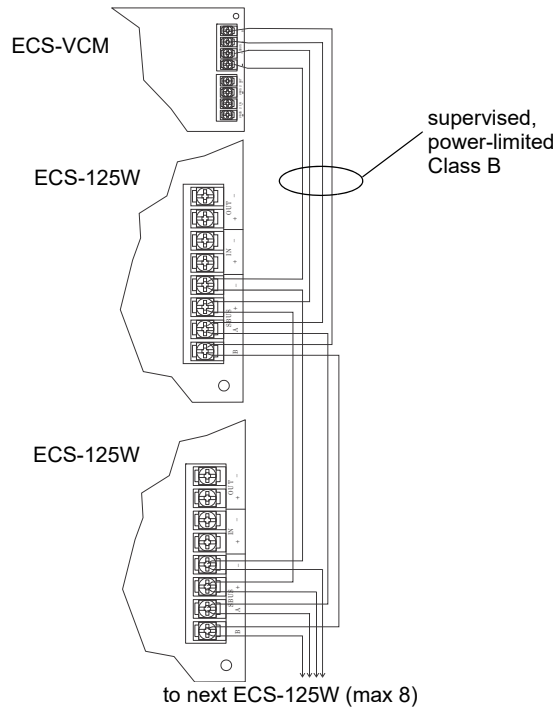

Figure 4.46 Connecting ECS-125W Amplifiers to the SBUS using the ECS-VCM

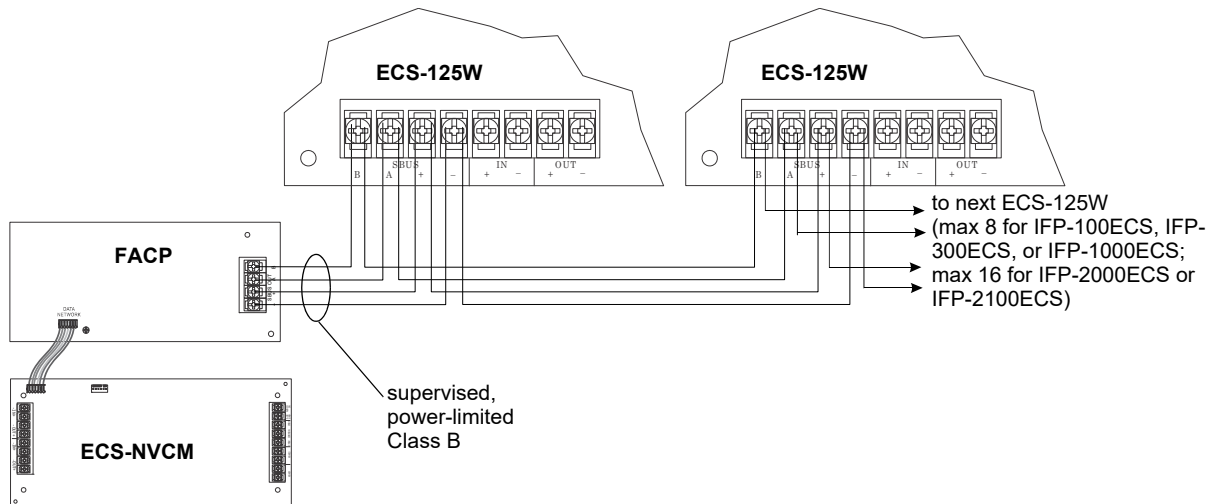

Figure 4.47 Connecting ECS-125W Amplifiers to the SBUS using the ECS-NVCM

See Section 4.11 for information on setting SBUS addresses.

4.6.8 Connecting AC Power

Connect the AC terminals to the power source as shown in Figure 4.48. It may be necessary for a professional electrician to make this connection.

The AC terminals are rated as 120 VAC, 60Hz or 240VAC, 50Hz.

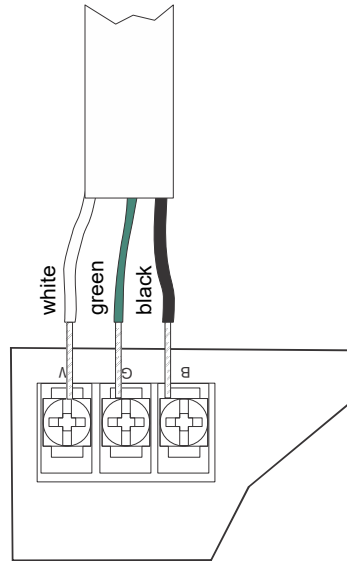

Figure 4.48 AC Connection

4.6.9 Backup Battery for ECS-125W

The following steps explain how to connect the batteries (refer to Figure 4.49):

1. Connect the black wire of the battery harness to the (-) side of the battery #2.
2. Connect the jumper wire provided from the positive (+) side of battery #2 to the negative side of battery #1.
3. Connect the red wire from the battery harness to the positive (+) side of battery #1.

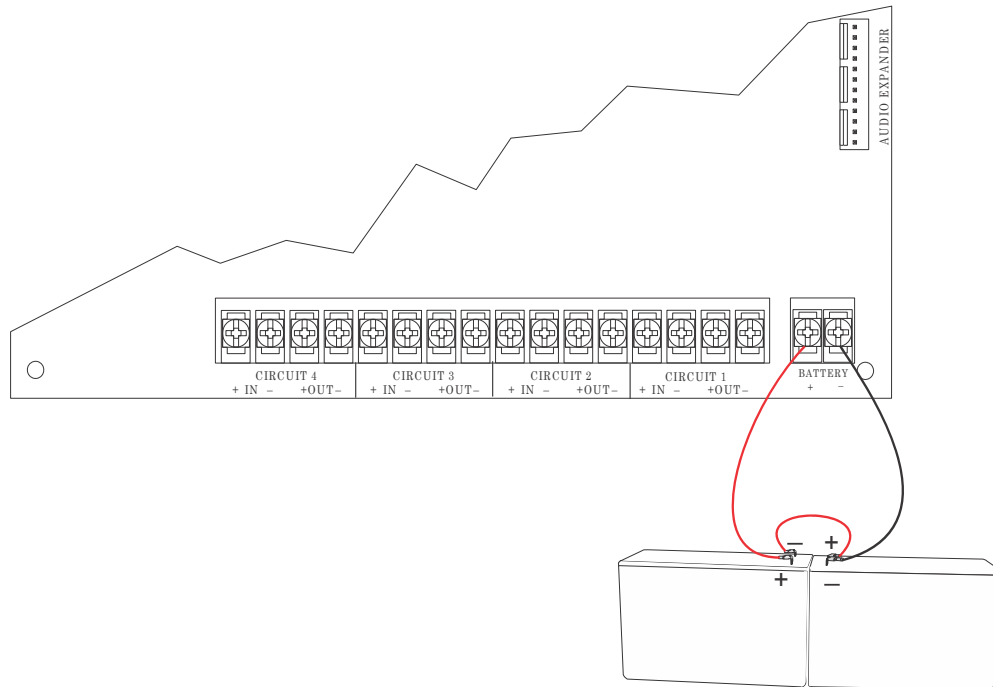

Figure 4.49 Battery Connection to ECS-125W

4.6.10 Calculating Current Draw and Standby Battery

This section helps you determine the current draw and standby battery needs for your installation (18 Ampere Hours maximum will fit in cabinet). These capacities have a built-in 20% derating factor. Complete the remaining instructions in Table 4.4.

Batteries larger than 18 AH will not fit in the main control cabinet, and must be housed in the RBB Accessory Battery Cabinet. The system supports a maximum of 35 AH batteries.

	Device	No. of Devices	Current Per Device	Standby Current	Alarm Current
	ECS-125W 120V	1	Standby: 375 mA	375mA	
			Alarm: 700 mA		700mA
	ECS-125W 240V	1	Standby: mA	mA	
			Alarm: mA		mA
	ECS-CE4	0 or 1	Standby: 20 mA	20mA	
			Alarm (All Channels): 180 mA		180mA
A	Current Subtotals:			mA	mA
	Notification Devices	Refer to device manual for number of devices and current ratings.			
B	Current Subtotals:			mA	mA
C	Total current rating of all devices in system (Line B) X 0.001			A	A
D	Number of standby hours (24 or 60 for NFPA 72)			H	
E	Multiply line C (standby current) and D: Total standby AH			AH	
F	Alarm sounding period in hours (For example, 5 minutes = 0.0833 hours):				H
G	Multiply line C (alarm current) and F: Total alarm AH				AH
H	Add lines E and G (AH = Ampere Hours): Total AH required			AH	

Table 4.4 Current Draw ECS-125W

4.7 Installing the ECS-DUAL50W

This section provides information on how to install the ECS-DUAL50W for use with the IFP-2100ECS, IFP-2000ECS, IFP-1000ECS, IFP-300ECS, and IFP-100ECS. The ECS-DUAL50W is available in a black cabinet as P/N ECS-DUAL50WB.* The ECS-DUAL50W is available with 240VAC input as ECS-DUAL50WHV.

4.7.1 ECS-DUAL50W Board Layout

Figure 4.50 shows the location of terminals, DIP switches and expander connection used in the installation of the ECS-DUAL50W.

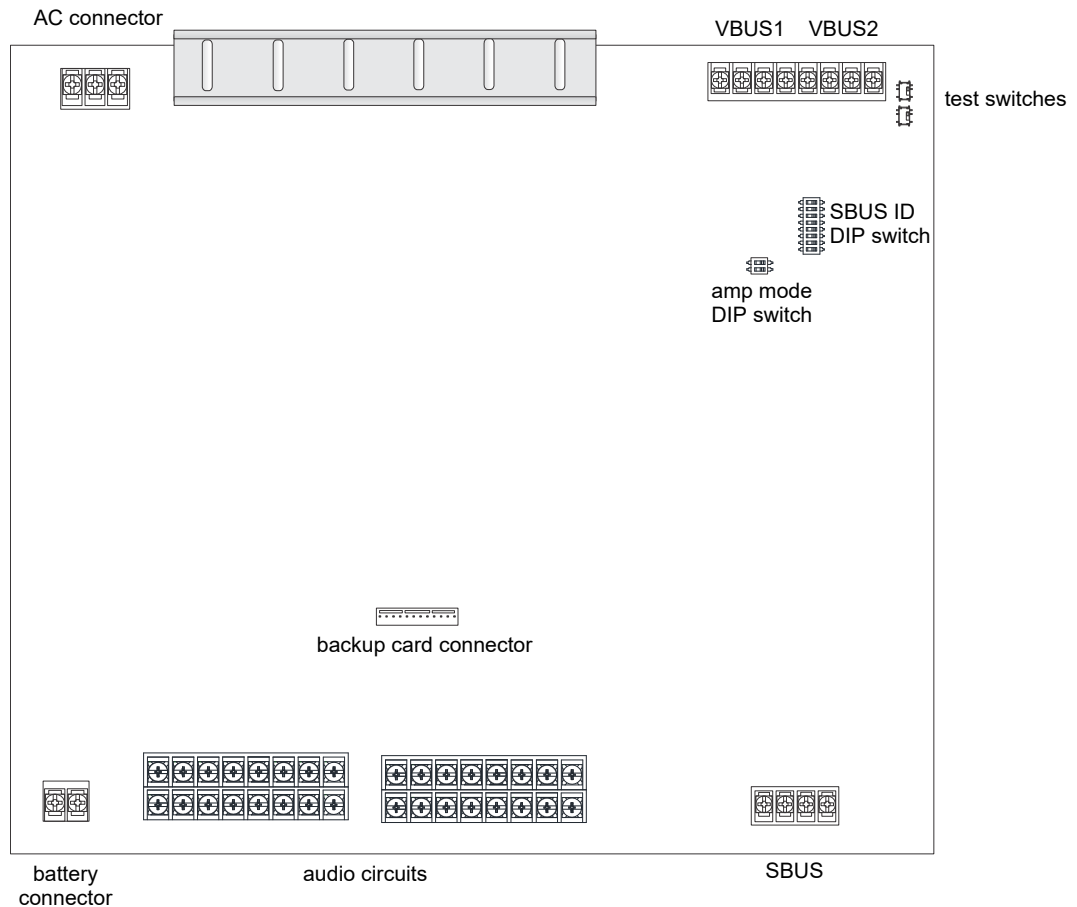

Figure 4.50 Components Layout for ECS-DUAL50W

4.7.2 Mounting the ECS-DUAL50W

The ECS-DUAL50W is equipped with a separate enclosure. Refer to Section 3.1 when selecting a mounting location for the ECS-DUAL50W.

The panel should be accessible to main drop wiring runs. It should be mounted as close to the center of the building as possible and located within a secured area, but should be accessible for testing and service.

Mount the control panel cabinet so it is firmly secured to the wall surface. When mounting on concrete, especially when moisture is expected, attach a piece of $\frac{3}{4}$ " plywood to the concrete surface and then attach the cabinet to the plywood. Also mount any other modules to the plywood.

The cabinet can be surface or flush-mounted. If you will be flush-mounting the cabinet, the hole for the enclosure should be 14.5" W x 24.75" H x 3.4375" D (36.8cm W x 62.9cm H x 8.7cm D). Do not flush-mount in a wall designated as a fire break. The outside dimensions of the cabinet are 16.1" W x 26.5" H x 4.125" D (40.9cm W x 67.3cm H x 10.5cm D).

Follow these steps to properly mount the cabinet.

Follow these steps to properly mount the cabinet.

1. Mark and pre-drill hole in the wall for the center top keyhole mounting bolts using the dimensions below.
2. Install center top fastener in the wall with the screw head protruding.
3. Place backbox over the top screw, level and secure.
4. Mark and drill the lower mounting holes.

5. Install remaining fasteners and tighten.

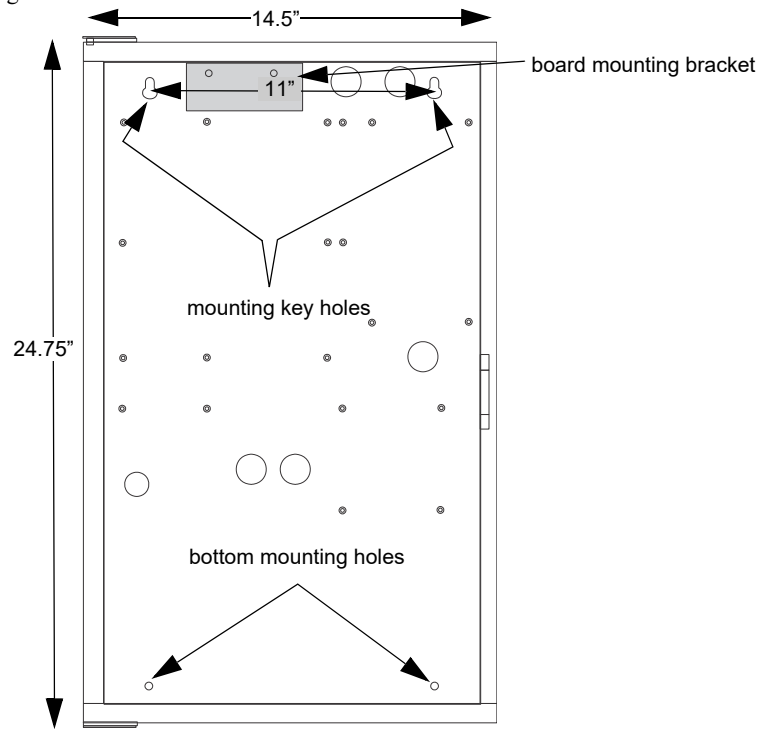

Figure 4.51 Cabinet Flush-Mount Dimensions and Mounting Hole Locations

4.7.3 Mounting the ECS-DUAL50WBD Board Only



NOTE: Installation and wiring of this device must be done in accordance with NFPA 72 and local ordinances.

1. Ensure AC and DC power have been removed from the panel.
2. If this module is a replacement for an existing ECS-DUAL50W, remove the screws which secure the board to the enclosure.

3. Secure the supplied “L-shaped” bracket to the top mounting bracket on the ECS-DUAL50WBD with the two mounting screws. See Figure 4.52.

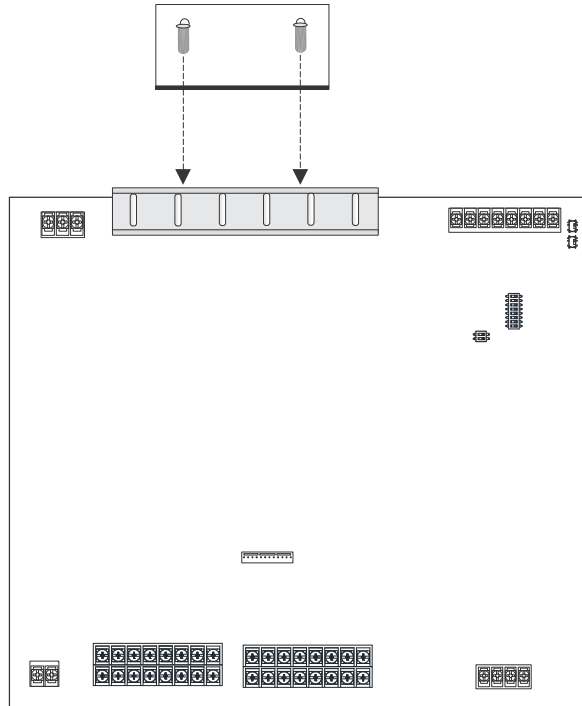

Figure 4.52 ECS-DUAL50WBD Mounting Bracket

4. Align the mounting holes on the bracket with the enclosure.
5. Secure the board to the enclosure.
6. Restore AC power and reconnect the backup batteries.

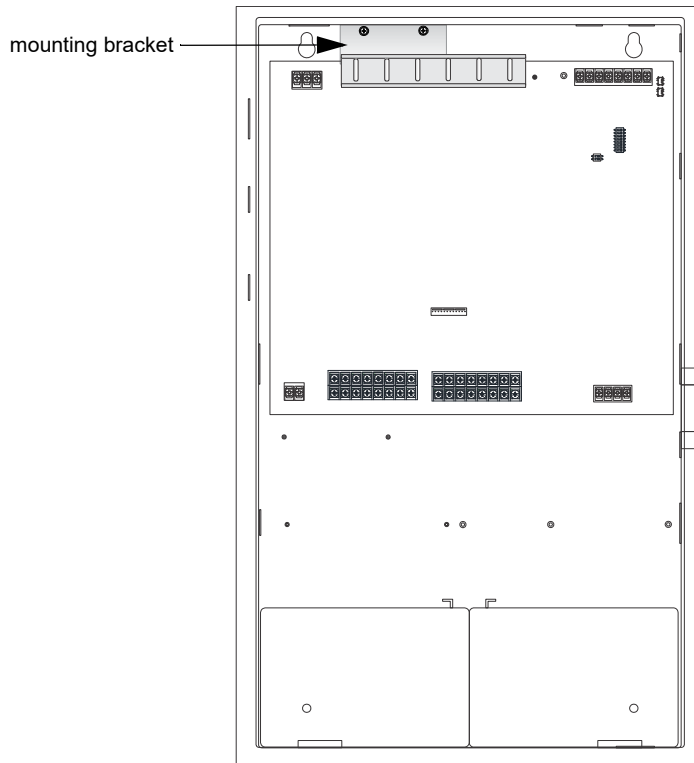

Figure 4.53 ECS-DUAL50WBD in Enclosure

4.7.4 Wiring Specifications

All wiring and devices installed in the system must meet the standards described in National Electrical Code (NFPA 70), NFPA Standard 72, and Life Safety Code (NFPA 101).

To avoid induced noise (transfer of electrical energy from one wire to another), keep input wiring isolated from high-current output and power wiring. Avoid pulling one multi-conductor cable for the entire panel.

Instead, separate the wiring as follows:

Maintain 0.25" spacing between each of these circuit types; as well as between power limited and non power-limited circuits.	Input/Output Type:	Wiring
	Non Power-Limited:	AC power, Standby batteries
	Power-Limited:	SBUS, VBUS
	Audio:	Speaker

DO NOT pull wires from different groups through the same conduit.

Twisted, shielded wire is recommended for all audio circuits to provide the maximum protection against EMI and AFI emission and susceptibility.

If using shielded cable, attach the shield to earth ground on the control panel.

For the same reasons, wiring within the cabinet should be routed around the perimeter of the cabinet. It should not cross the printed circuit board where it could induce noise into the sensitive microelectronics or pick up unwanted RF noise from the high speed circuits.



NOTE: Ground Fault Impedance to any Terminal is 0Ω .

High frequency noise, such as that produced by the inductive reactance of a speaker or bell, can also be reduced by running the wire through ferrite beads or by wrapping it around a ferrite toroid core.

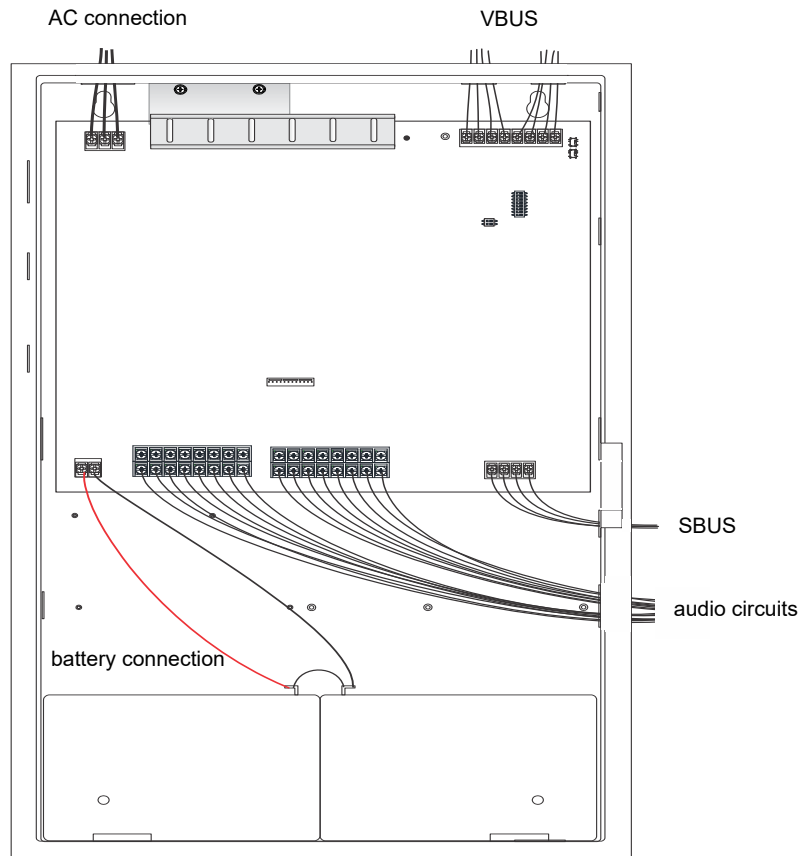

Figure 4.54 Wire Routing Example for ECS-DUAL50W

4.7.5 Speaker Wiring

Each ECS-DUAL50W supplies eight NACs for speaker connection. The speaker circuit can be supervised and wired Class B or Class A. The speaker circuits are capable of 50 watts (each) at 25 Vrms or 70.7 Vrms.

Wiring Lengths

Number Of Speakers		Total Load		Wire Distance in Feet			
@1/2 W	@1 W	Vrms	Watts	18 AWG	16 AWG	14 AWG	12 AWG
10	5	25Vrms	5W	3900	6200	9860	15680
		70Vrms		25000	39700	63200	100520
20	10	25Vrms	10W	2125	3380	5375	8540
		70Vrms		15200	24150	38400	61100
30	15	25Vrms	15W	1460	2320	3690	5870
		70Vrms		11000	17500	27800	44200
40	20	25Vrms	20W	1100	1750	2780	4420
		70Vrms		8500	13510	21500	34175
52	26	25Vrms	26W	760	1200	1920	3050
		70Vrms		6100	9700	15400	24520
80	40	25Vrms	40W	550	875	1390	2200
		70Vrms		4100	6500	10360	16480
100	50	25Vrms	50W	450	715	1130	1800
		70Vrms		3500	5560	8850	14070

Table 4.5 Wire Lengths



NOTE: The above table assumes a uniform distribution of the speakers, and that a max of 20% voltage drop on the last speaker is allowed

Class B Speaker Configuration for ECS-DUAL50W

Figure 4.55 illustrates how to wire speakers to the control panel using Class B supervision.

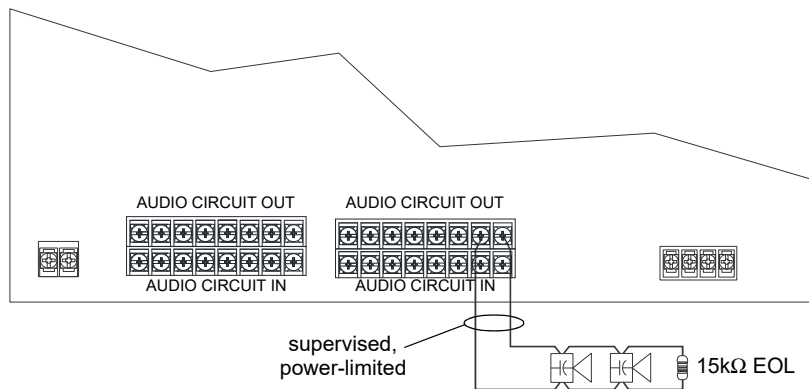

Figure 4.55 Class B Speaker Configuration

Class A Speaker Configuration for ECS-DUAL50W

Figure 4.56 illustrates how to wire speakers to the control panel using Class A wiring.

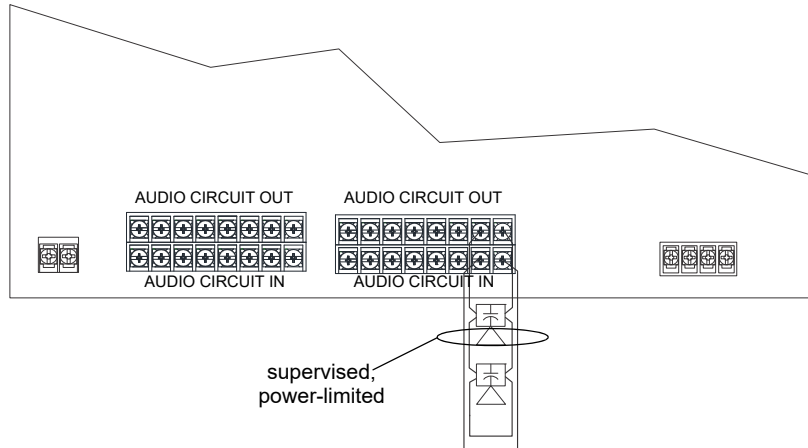

Figure 4.56 Class A Speaker Configuration

4.7.6 VBUS Wiring

The VBUS is an analog voice bus that carries the recorded voice messages from the ECS-VCM or ECS-NVCM to the ECS-DUAL50W amplifiers, or the voice messages generated from a system microphone to the ECS-DUAL50W amplifiers. The maximum resistance on the VBUS is 20Ω.

The ECS-DUAL50W supports two VBUS channels. The wiring method is the same for both channels. VBUS1 and VBUS2 should never be wired together.

Connect the VBUS from the ECS-VCM to the ECS-DUAL50W amplifiers as shown in Figure 4.57 and Figure 4.58 or Figure 4.59 and Figure 4.60 for ECS-NVCM.

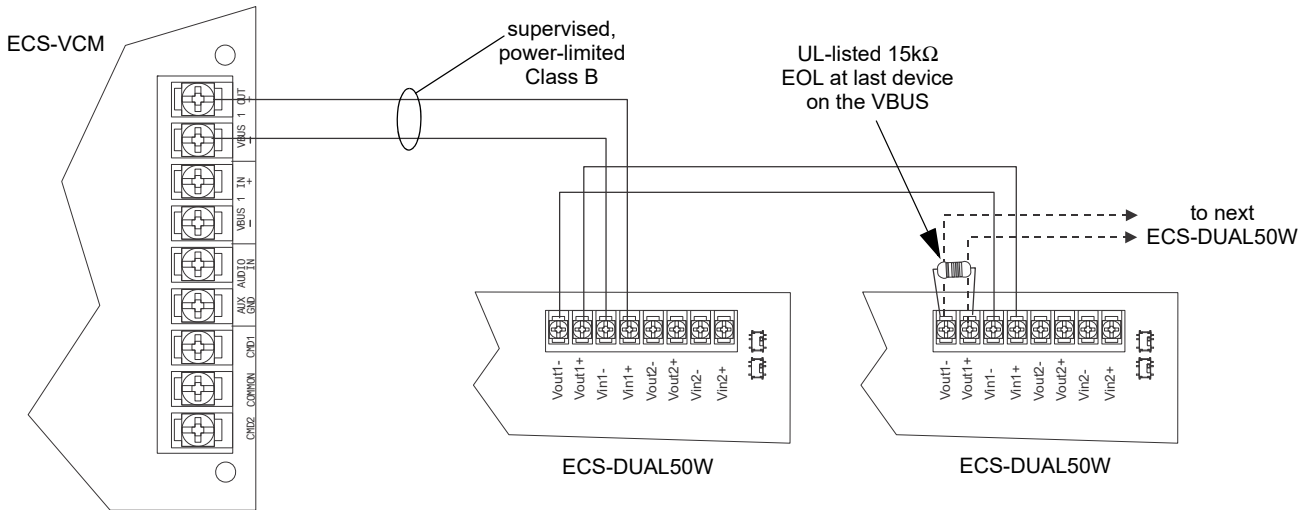

Figure 4.57 VBUS Wiring for Single Channel for ECS-VCM

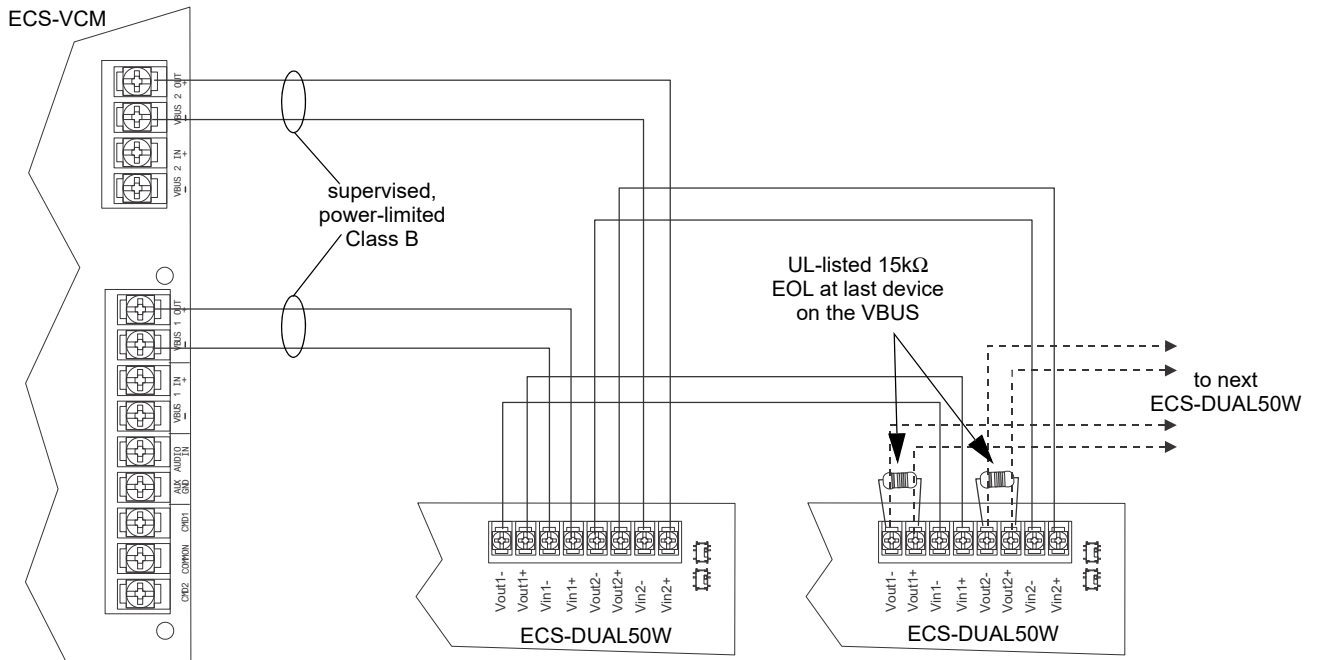

Figure 4.58 VBUS2 Wiring for Dual Channel for ECS-VCM

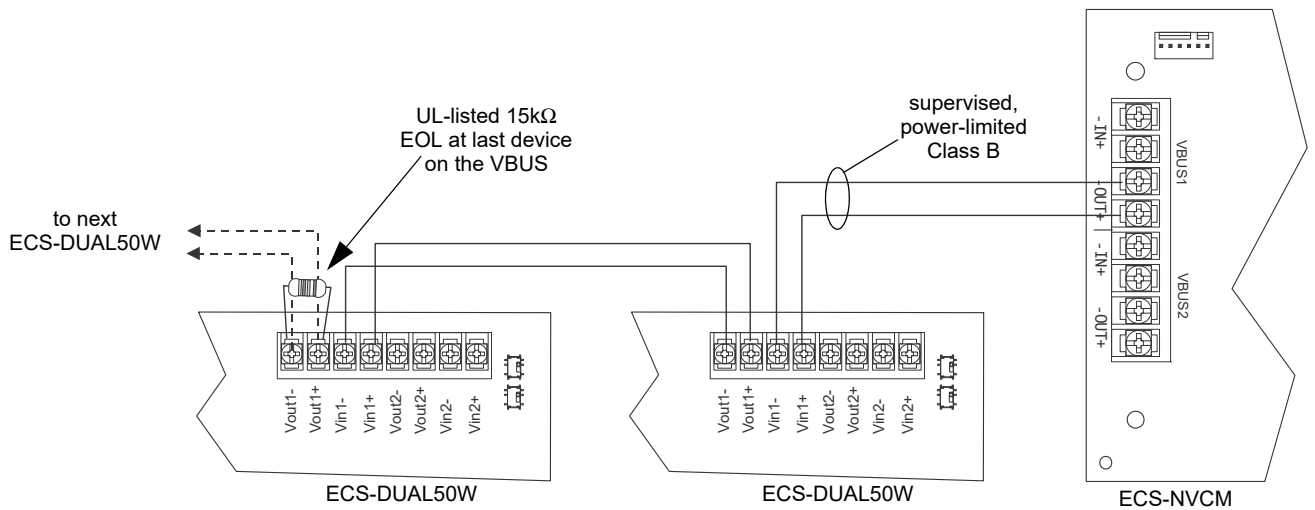

Figure 4.59 VBUS Wiring for Single Channel for ECS-NVCM

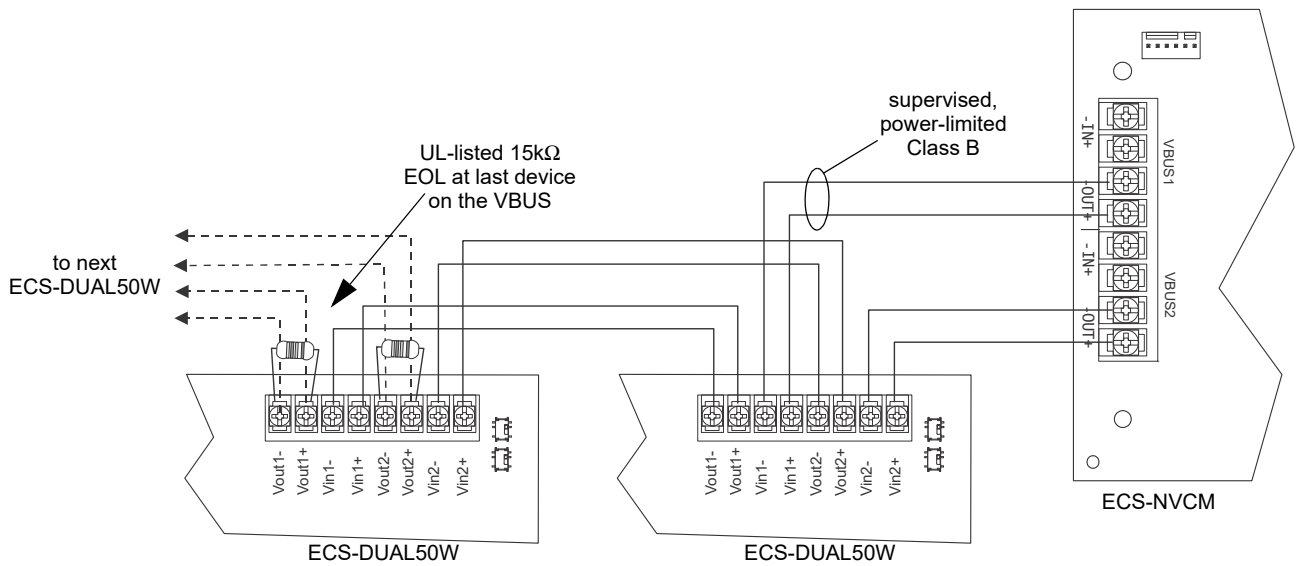

Figure 4.60 VBUS2 Wiring for Dual Channel for ECS-NVCM

4.7.7 SBUS Wiring

This section contains information on how to connect ECS-DUAL50Ws (up to 8 for IFP-100ECS, ECS-300ECS, and IFP-1000ECS or up to 16 for the IFP-2000ECS or ECS-2100ECS) onto the main control SBUS. Refer to Section 4 of the FACP Installation manual for SBUS specifications. Wire the SBUS to either the ECS-VCM or SBUS Out terminals on the FACP as shown in Figure 4.61.

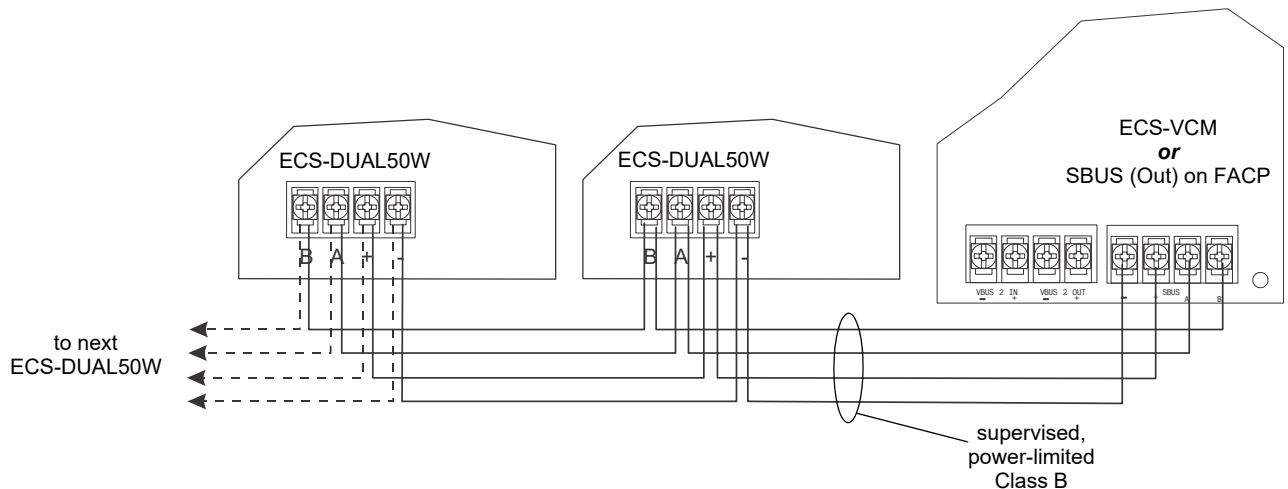

Figure 4.61 Connecting ECS-DUAL50W to the SBUS

See Section 4.11 for information on setting SBUS addresses.

4.7.8 Setting the ECS-DUAL50W Backup Mode

When the ECS-DUAL50W is connected to an IFP-100ECS or IFP-1000ECS version 13 or prior, see Figure 4.62 below to set the amplifier mode. If using version 14 or later, the mode is set using HFSS (Honeywell Fire Software Suite) and the DIP switch mode selector is ignored. When the ECS-DUAL50W is connected to an IFP-2000ECS, IFP-300ECS, or the IFP-2100ECS, the mode is set using the HFSS Software Suite and the DIP switch mode selector is ignored.

The amplifier modes are as follows:

- 50 Watt with backup - Amp A powers audio circuits 1 - 8. Amp A is backed up by onboard Amp B. (Default, DIP setting at position 2).
- 100 Watt with no backup - Amp A powers audio circuits 1 - 4. Amp B powers audio circuits 5 - 8. There is no backup. (DIP setting at position 1).
- 100 Watt with backup (requires ECS-50WBU) - Amp A powers audio circuits 1 - 4. Amp B powers audio circuits 5 - 8. The ECS-50WBU will back up Amp A or Amp B but never both. (DIP setting at position 3).

If the ECS-DUAL50W is connected to an IFP-2000ECS or ECS-2100ECS system and configured to operate in a dual channel setup, Amp A and/or Amp B is not restricted to which audio circuits it can power. However, both can never power the same audio circuit.

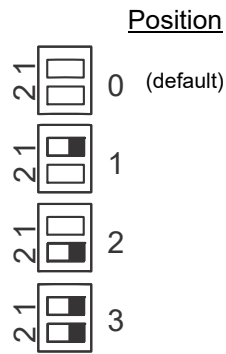

Figure 4.62 DIP Switch Modes

4.7.9 Test Switches

See Figure 4.50 on page 45 for the location of the Test slide switches.

SW1 - AMP A

Switch should be moved to the “ON” position for normal operation. Move this switch to the “Test” position to test backup amplifier.

SW2 - AMP B

Switch should be moved to the “ON” position for normal operation. Move this switch to the “Test” position to test backup amplifier.



NOTE: Allow up to 3 minutes for backup amplifier to engage.

4.7.10 Connecting AC Power

At installation, connect the AC terminals to the power source as shown in Figure 4.63. It may be necessary for a professional electrician to make this connection.

The AC terminals are rated as 120VAC, 60 Hz or 240VAC, 50/60 Hz.

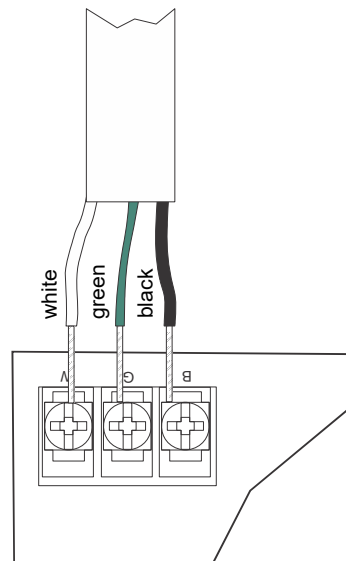

Figure 4.63 AC Connection

4.7.11 Backup Battery for ECS-DUAL50W

The following steps explain how to connect the batteries (refer to Figure 4.64):

1. Connect the black wire of the battery harness to the (-) side of the battery #2.
2. Connect the jumper wire provided from the positive (+) side of battery #2 to the negative side of battery #1.

3. Connect the red wire from the battery harness to the positive (+) side of battery #1.

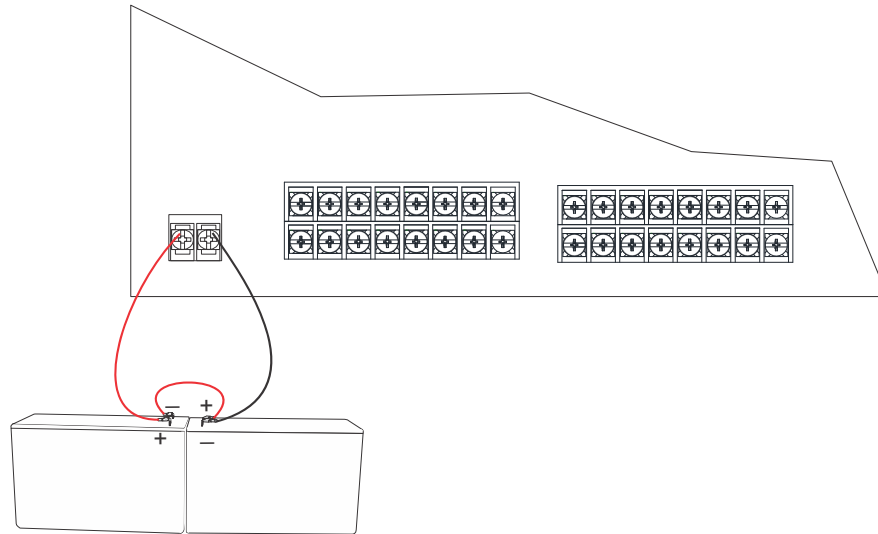

Figure 4.64 Battery Connection to ECS-DUAL50W

4.7.12 Calculating Current Draw and Standby Battery

This section helps determine the current draw and standby battery needs for your installation (18 AH maximum will fit in cabinet). Complete the remaining instructions in Table 4.6.

Batteries larger than 18 AH will not fit in the main control cabinet, and must be housed in the RBB Accessory Battery Cabinet. The system supports a maximum of 35 AH.

Device	No. of Devices	Current Per Device	Standby Current	Alarm Current
ECS-DUAL50W 25V	1	Standby: 110 mA	110 mA	
		Alarm: 1.2 A		1.2 A
ECS-DUAL50W 70.7V	1	Standby: 110 mA	110 mA	
		Alarm: 1.4 A		1.4A
ECS-50WBU	1	Standby: 40 mA	40 mA	
		Alarm: 110 mA		110 MA
A	Current Subtotals:		mA	mA
Notification Devices		Refer to device manual for number of devices and current ratings.		
B	Current Subtotals:		mA	mA
C	Total current rating of all devices in system (Line B) X 0.001		A	A
D	Number of standby hours (24 or 60 for NFPA 72)		H	
E	Multiply line C (standby current) and D: Total standby AH		AH	
F	Alarm sounding period in hours (For example, 5 minutes = 0.0833 hours):			H
G	Multiply line C (alarm current) and F: Total alarm AH			AH
H	Add lines E and G (AH = Ampere Hours): Total AH required		AH	

Table 4.6 Current Draw ECS-DUAL50W

4.8 Installing the ECS-50WBU

The ECS-50WBU provides backup capability when operating the ECS-DUAL50W in the 100 watt with backup mode for both single and dual channel setups. The ECS-50WBU mounts on the ECS-DUAL50W board on the standoffs provided.

4.8.1 ECS-DUAL50W Board Layout

Figure 4.65 shows the location of the ECS-50WBU on the ECS-DUAL50W board.

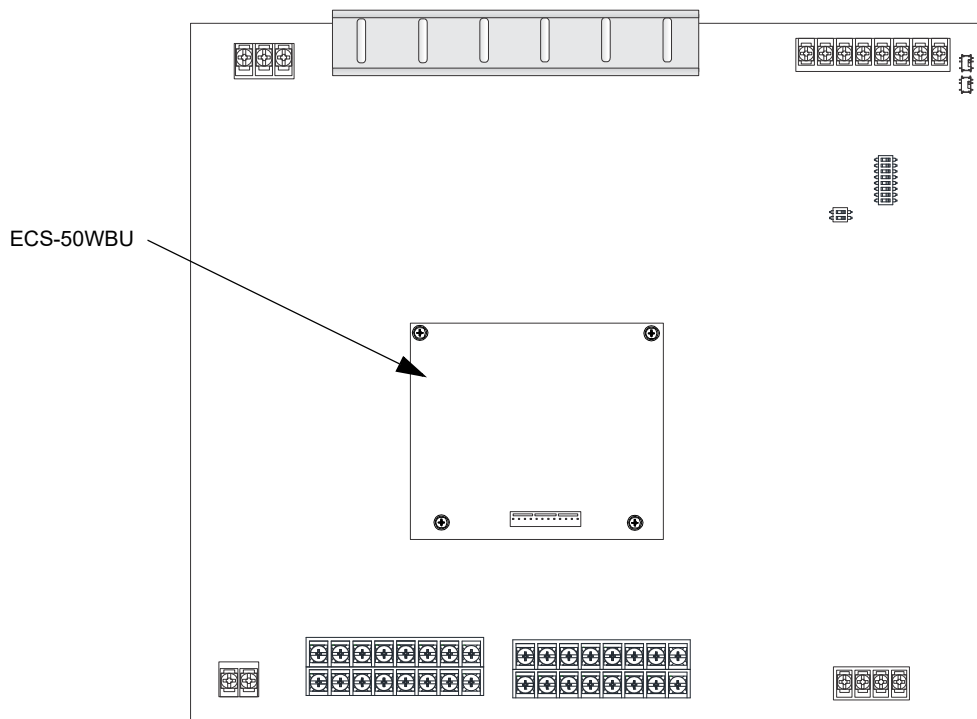

Figure 4.65 ECS-50WBU Mounting Location

4.8.2 Installing the ECS-50WBU

Follow these steps to install the ECS-50WBU.

1. Ensure all power supplied to the ECS-DUAL50W is removed.
2. Secure the four standoffs supplied with the ECS-DUAL50W to the board as shown in Figure 4.66.
3. Connect the backup amplifier cable harness (P/N 50116775-001) from the connector labeled “Backup Amplifier” on the ECS-DUAL50W to the connector on the ECS-50WBU.

- Using the four supplied screws, secure the ECS-50WBU to the standoffs.

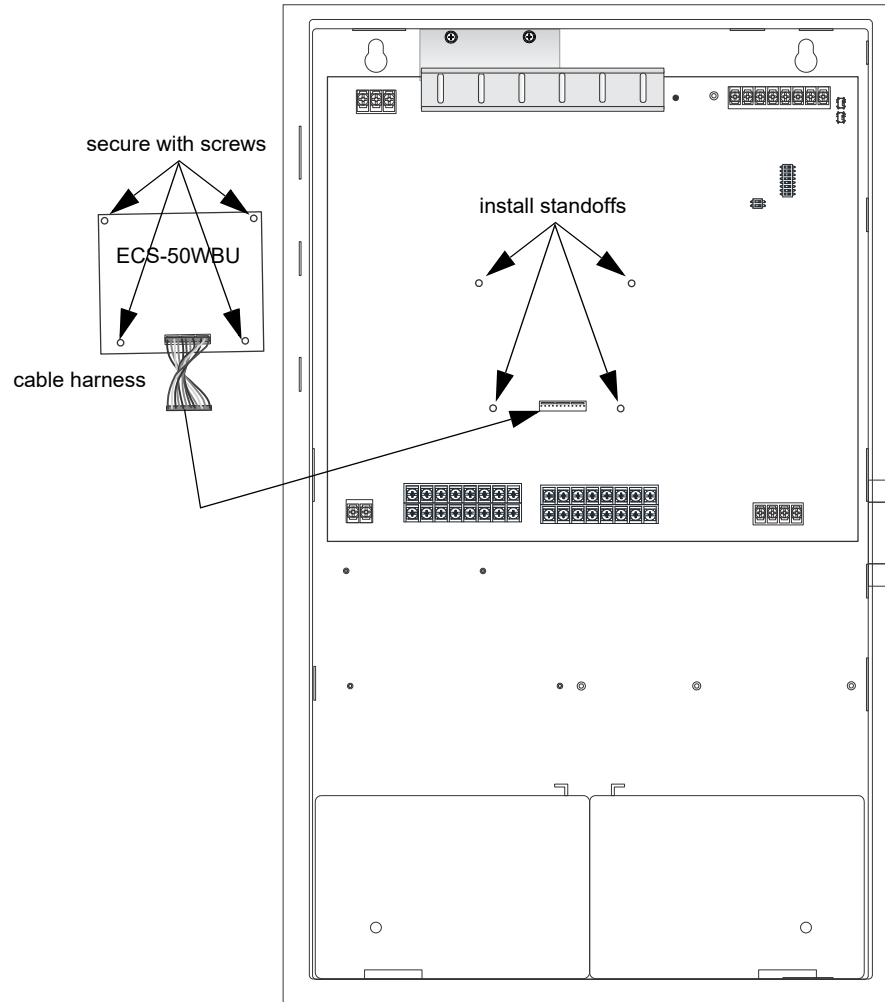

Figure 4.66 Mounting the ECS-50WBU

4.9 Installing the ECS-CE4

The ECS-CE4 adds four audio circuits to the ECS-50W and ECS-125W. The ECS-CE4 mounts inside the ECS-50W or ECS-125W cabinet. Follow these steps to install the ECS-CE4.

- Align the ECS-CE4 over the PEM studs on the backbox.

- Secure the ECS-CE4 to the backbox using the four supplied screws as shown in Figure 4.67.

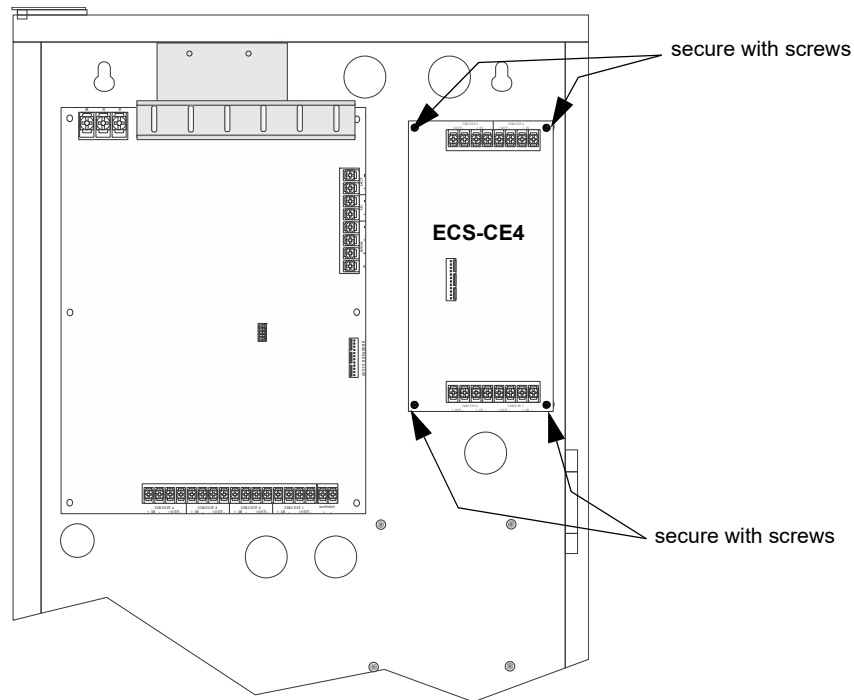

Figure 4.67 Mounting the ECS-CE4

- Connect the audio expander cable harness (P/N 130426) from the connector labeled “Audio Expander” on the ECS-50W or ECS-125W to the connector on the ECS-CE4 as shown in Figure 4.68.

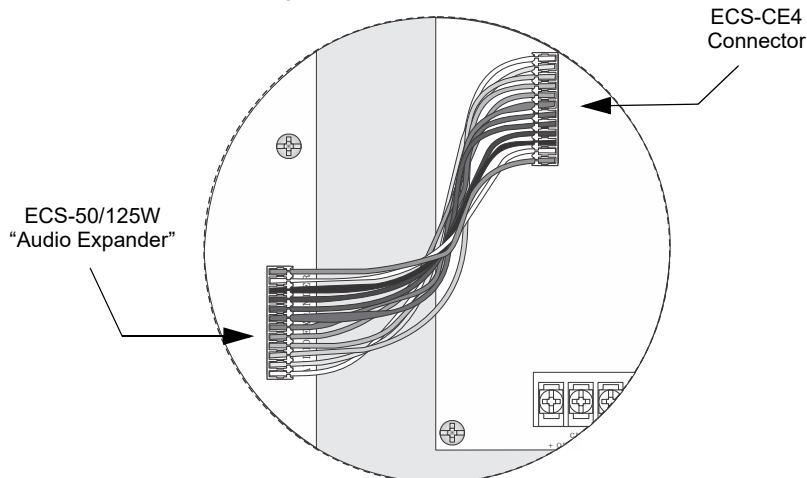

Figure 4.68 Audio Expander Wire Harness Connections

- Wire audio circuits as shown in “Speaker Wiring” on page 26.

4.10 Installing the ECS-RVM

The ECS-RVM Remote Voice Module is contained within the ECS-RCU, ECS-LOC, or ECS-LOC2100 Local Operator Console. It provides a supervised microphone for live communication and an interface for the Emergency Communication System.

4.10.1 ECS-RVM Board Layout

The following is description of the ECS-RVM remote voice module components.



NOTE: The ECS-VCM and ECS-RVM circuit boards look similar, but they are not interchangeable. The ECS-VCM is mounted in the IFP-100ECS, IFP-1000ECS, and IFP-2000ECS while the ECS-RVM is mounted in the ECS-LOC cabinet.

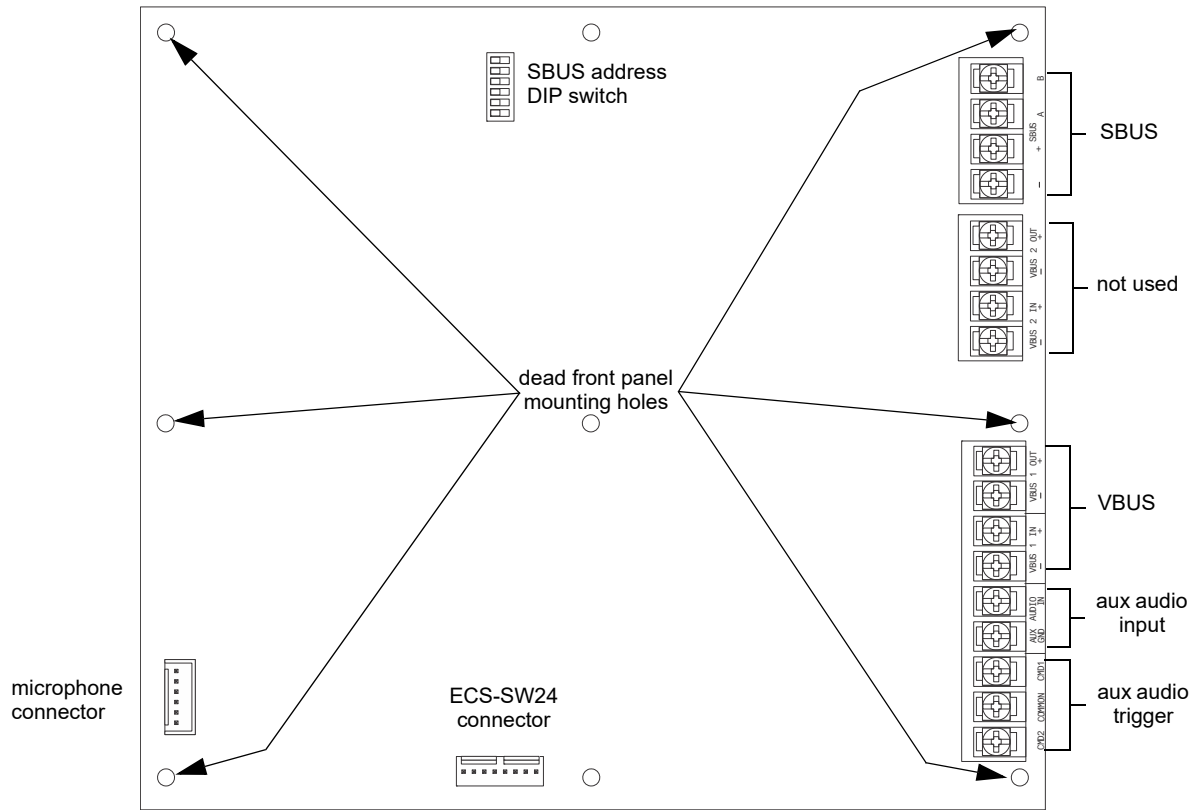

Figure 4.69 Back View of ECS-RVM

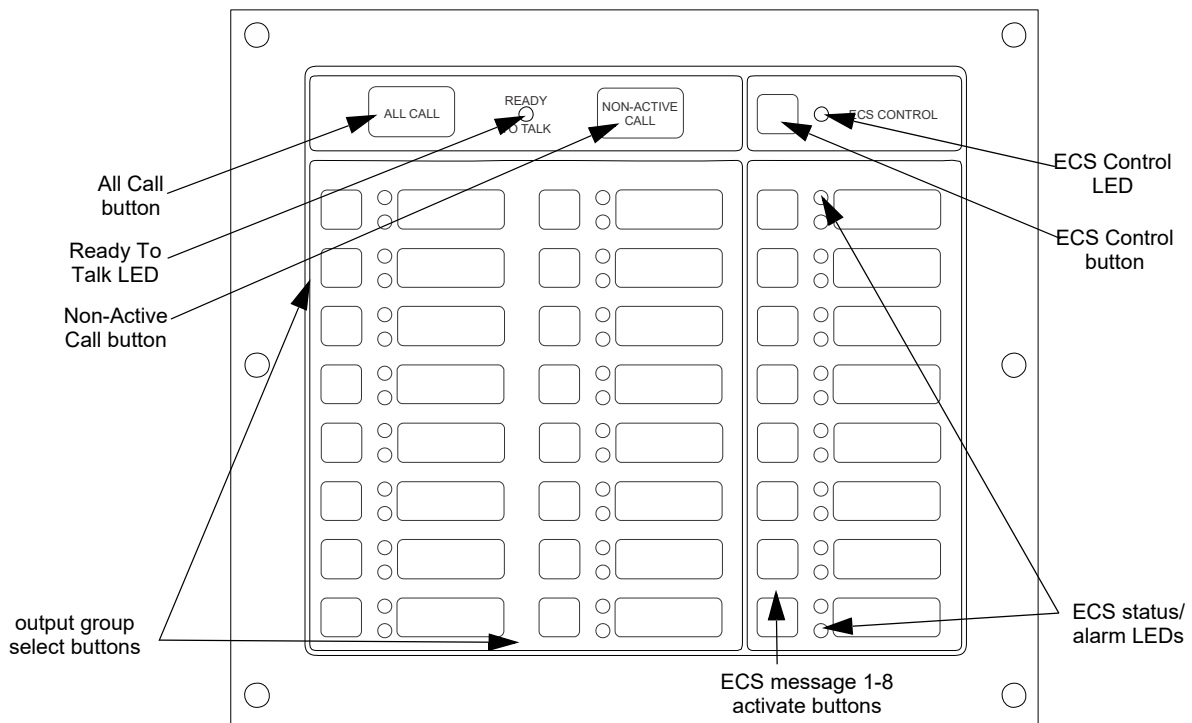

Figure 4.70 Front View of ECS-RVM

4.10.2 Wiring the ECS-RVM

1. Refer to Figure 4.71 to properly connect the ECS-RVM to the FACP's SBUS.

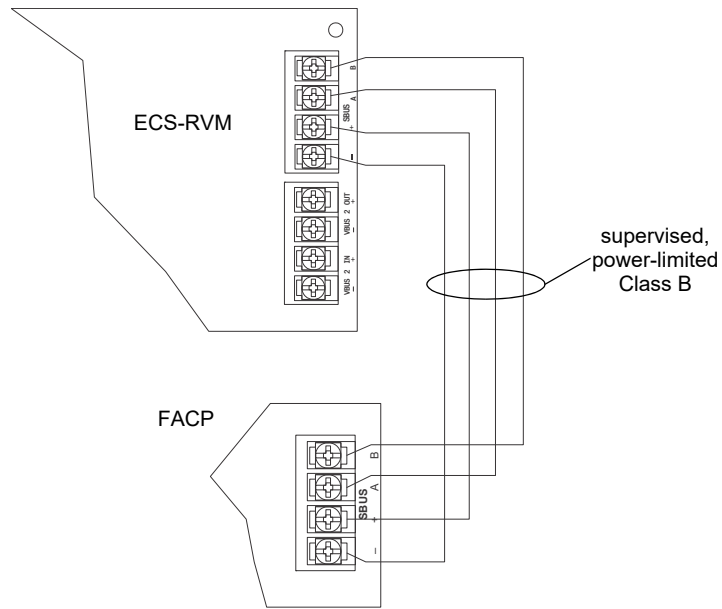

Figure 4.71 ECS-RVM SBUS Connections

2. Connect the SBUS to the annunciator and ECS-RVM. See Figure 4.72.

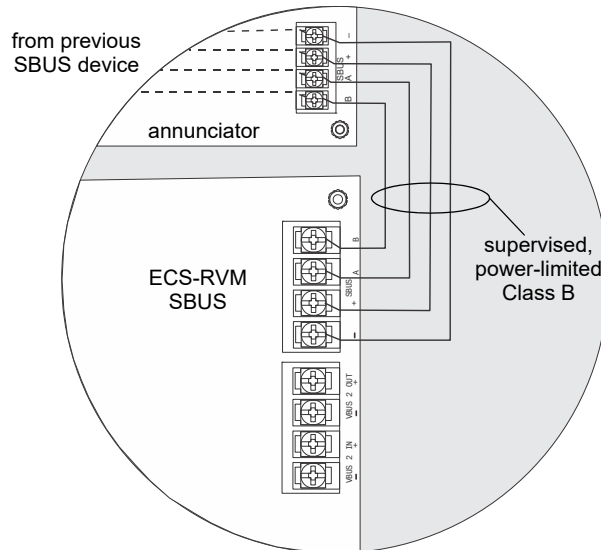

Figure 4.72 SBUS wiring for ECS-RVM

3. Set the SBUS address on the annunciator and the ECS-RVM board. See Section 4.11 for more information.
4. Connect the ECS-RVM to the VBUS, ECS-125W, and ECS-VCM as shown in Figure 4.73 or the ECS-NVCM as shown in Figure 4.74.

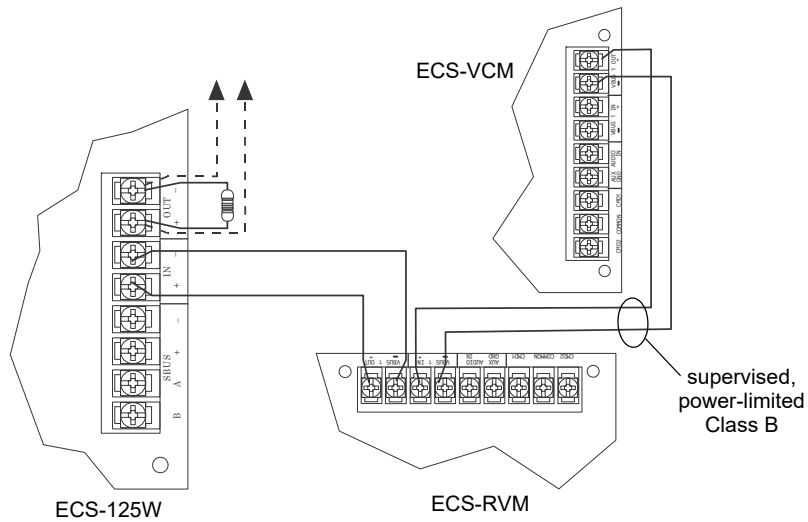

Figure 4.73 VBUS and ECS-125W Wiring for ECS-RVM using the ECS-VCN

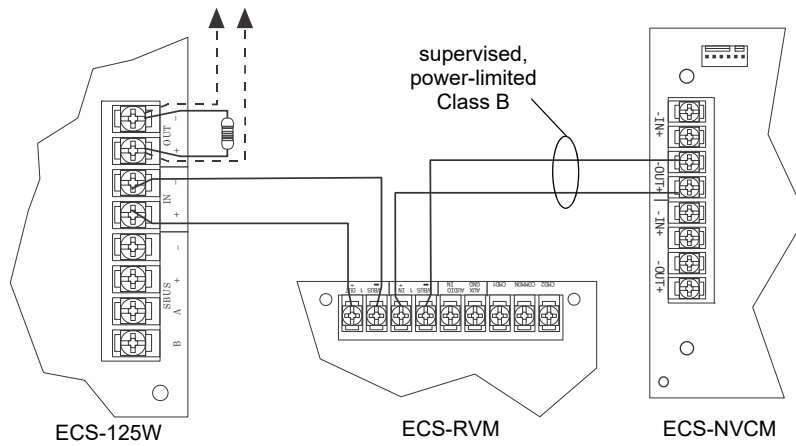

Figure 4.74 VBUS and ECS-125W Wiring for ECS-RVM using the ECS-NVCN

4.10.3 Installing the Microphone

To install the microphone follow these steps:

1. Clip the microphone onto the microphone clip.
2. Insert microphone cord through hole at the bottom of the dead front panel. See Figure 4.75.

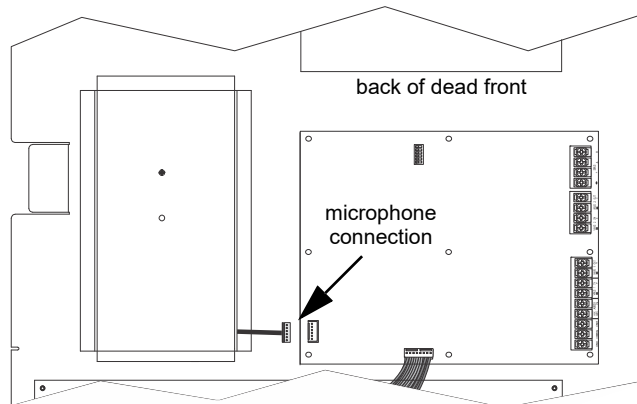

Figure 4.75 Microphone Cord Inserted Through Dead Front Panel Hole

- Attach strain relief clip to microphone cord. The strain relief clip should have about 2.75" of microphone cord through it. .

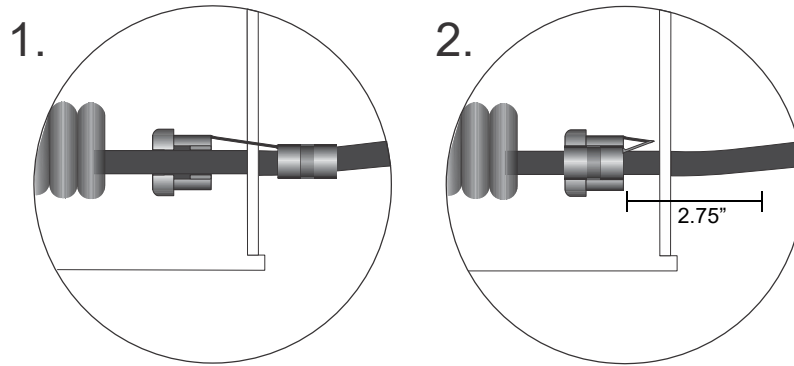

Figure 4.76 Installing Strain Relief Clip

- Push the strain into the hole in the dead front panel.

4.10.4 To Remove the ECS-RVM

To remove the ECS-RVM follow these steps:

- Remove AC power and disconnect batteries from the main control panel.
- Disconnect the SBUS connections from the SBUS terminals on the ECS-RVM. Refer to Figure 4.72.
- Disconnect any devices connected to the VBUS. Refer to Figure 4.73 and Figure 4.74.
- Unplug the microphone from the microphone connector. See Figure 4.75.
- Remove the six 0.25" hex nuts that hold the ECS-RVM in place.
- Lift the ECS-RVM off of the dead front panel.

4.11 Addressing SBUS Devices

When installing a hardware module (such as 5815XL, 6815, 5824, RA-1000, RA-100, RA-2000, 5496, RPS-1000, 5865-3 or 5865-4, ECS-50W, ECS-125W, ECS-DUAL50W, ECS-VCM, ECS-NVCM and ECS-RVM), use the DIP switches on the module to assign an ID# to the module.

Figure 4.77 shows all possible DIP switch positions and their correlation to a numerical ID. For example, to select ID 2, place DIP switch 2 in the up position.

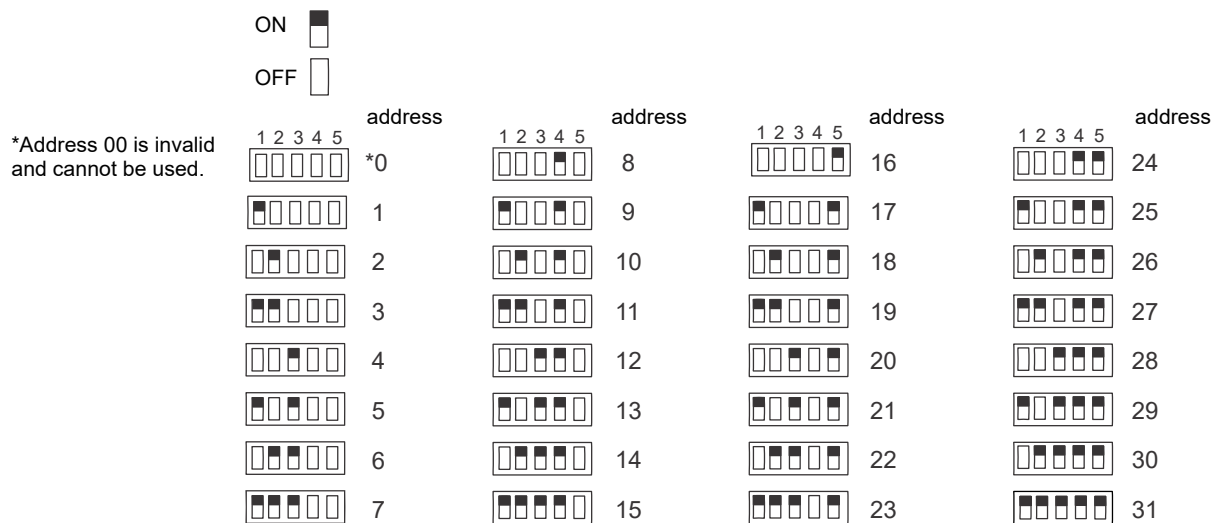

Figure 4.77 Possible Module Addresses

Panel Security

Panel installation / maintenance security checklist

System Description: _____

System Location: _____

Installer: _____ Date: _____

Complete the following cyber security tasks for each panel installation.

- ✓ Install the panel in a secure location considering both software and hardware vulnerabilities.
- ✓ Change the default password to a unique password.
- ✓ Securely configure networks and firewalls.
- ✓ Assess security risks.
- ✓ Develop a Disaster and Recovery Plan.
- ✓ Develop a Backup and Recovery Strategy.
- ✓ Install, configure and keep anti virus software updated on all computers which access the panel
- ✓ Keep operating system updated on all computers which access the panel.
- ✓ Deliver all required system information upon delivery to the system owner.
- ✓ Train end-users on security maintenance tasks upon system delivery.
- ✓ For decommissioning, dispose of data securely.
- ✓ Ensure the Ethernet cable is removed from the FACP when not being utilized for configuration or for reporting purposes.

Security and Data Protection

Communication Security - Level 1

Stored Data Security - Level 0

Physical Security - Level 1

Access Control Security - Level 1

Manufacturer Warranties and Limitation of Liability

Manufacturer Warranties. Subject to the limitations set forth herein, Manufacturer warrants that the Products manufactured by it in its Northford, Connecticut facility and sold by it to its authorized Distributors shall be free, under normal use and service, from defects in material and workmanship for a period of thirty six months (36) months from the date of manufacture (effective Jan. 1, 2009). The Products manufactured and sold by Manufacturer are date stamped at the time of production. Manufacturer does not warrant Products that are not manufactured by it in its Northford, Connecticut facility but assigns to its Distributor, to the extent possible, any warranty offered by the manufacturer of such product. This warranty shall be void if a Product is altered, serviced or repaired by anyone other than Manufacturer or its authorized Distributors. This warranty shall also be void if there is a failure to maintain the Products and the systems in which they operate in proper working conditions.

MANUFACTURER MAKES NO FURTHER WARRANTIES, AND DISCLAIMS ANY AND ALL OTHER WARRANTIES, EITHER EXPRESSED OR IMPLIED, WITH RESPECT TO THE PRODUCTS, TRADEMARKS, PROGRAMS AND SERVICES RENDERED BY MANUFACTURER INCLUDING WITHOUT LIMITATION, INFRINGEMENT, TITLE, MERCHANTABILITY, OR FITNESS FOR ANY PARTICULAR PURPOSE. MANUFACTURER SHALL NOT BE LIABLE FOR ANY PERSONAL INJURY OR DEATH WHICH MAY ARISE IN THE COURSE OF, OR AS A RESULT OF, PERSONAL, COMMERCIAL OR INDUSTRIAL USES OF ITS PRODUCTS.

This document constitutes the only warranty made by Manufacturer with respect to its products and replaces all previous warranties and is the only warranty made by Manufacturer. No increase or alteration, written or verbal, of the obligation of this warranty is authorized. Manufacturer does not represent that its products will prevent any loss by fire or otherwise.

Warranty Claims. Manufacturer shall replace or repair, at Manufacturer's discretion, each part returned by its authorized Distributor and acknowledged by Manufacturer to be defective, provided that such part shall have been returned to Manufacturer with all charges prepaid and the authorized Distributor has completed Manufacturer's Return Material Authorization form. The replacement part shall come from Manufacturer's stock and may be new or refurbished. THE FOREGOING IS DISTRIBUTOR'S SOLE AND EXCLUSIVE REMEDY IN THE EVENT OF A WARRANTY CLAIM.

Warn-HL-08-2009.fm

Honeywell Fire Systems
12 Clintonville Road
Northford, CT 06472-1610
203-484-7161
www.farenhyt.com

151455 | H | 02-22
©2022 Honeywell International Inc.

Honeywell