

L-Series with LED Outdoor Selectable-Output Horn Strobes and Strobes



3825 Ohio Avenue, St. Charles, Illinois 60174
800/736-7672, FAX: 630/377-6495
www.systemsensor.com

Manual is for use with the following models:

Horn Strobes

Compact Wall Mount Horn Strobes: P2GRKLED, P2GRKLED-P, P2GRKLED-B, P2GWKLED, P2GWKLED-P, P2GWKLED-B
Standard Ceiling Mount Horn Strobes: PC2RKLED, PC2RKLED-P, PC2RKLED-B, PC2WKLED, PC2WKLED-P, PC2WKLED-B

Two-Wire Strobes

Compact Wall Mount Strobes: SGRKLED, SGRKLED-P, SGRKLED-B, SGWKLED, SGWKLED-P, SGWKLED-B, SGBKLED*
Standard Ceiling Mount Strobes: SCRKLED, SCRKLED-P, SCRKLED-B, SCWKLED, SCWKLED-P, SCWKLED-B

Language designators: “-B” are bilingual (English/French). “-P” are plain versions (no wording).

NOTE: When replacing outdoor units; device and back box must be replaced.

*NOTE: Model SGBKLED is UL listed for General Signaling

Table of Contents

- Section 1: Introduction 2**
 - 1.1 Product Specifications 2
 - 1.2 Dimensions and Mounting Options 2
 - 1.3 Before Installing 2
 - 1.4 General Description 2
 - 1.5 Fire Alarm System Considerations 2
 - 1.6 System Design 3
- Section 2: Configurations for Notification Appliances 4**
 - 2.1 Available Tones 4
 - 2.2 Available Candela Settings 4
 - 2.3 Current Draw and Audibility ratings 5
- Section 3: Installation 7**
 - 3.1 Wiring and Mounting 7
 - 3.2 Wiring Diagrams 7
 - 3.3 Install Back Box 7
 - 3.4 Install Weatherproof Back Plate and Appliance 8

Section 1: Introduction

1.1 Product Specifications

Standard Operating Temperature:	-40°F to 151°F (-40°C to 66°C)
Humidity Range:	0 to 95 ±5%
Strobe Flash Rate	1 flash per second
Nominal Voltage:	Regulated 24 VDC
Operating Voltage Range:	16 to 33V (24V nominal)
Wiring between Fire Alarm Control Panel (FACP) and weatherproof back plate:	12 to 18 AWG
Environmental Considerations:	Enclosure meets rating requirements for Type 4X (UL50E), NEMA 4X (FM), and IP56 as a standalone device (without the backbox)

1.2 Dimensions and Mounting Options

Wall Mounted Product	Length	Width	Depth	Mounting Options
Strobe and Horn Strobe (including lens)	5.84" (148 mm)	3.76" (95.5 mm)	1.87" (47.5 mm)	Two-Wire Outdoor Products: SBBGRL (wall), SBBGWL
Strobe and Horn Strobe (including lens) with SBBGRL Surface Mount Back Box	5.84" (148 mm)	3.76" (95.5 mm)	3.72" (94.5 mm)	
NOTE: SBBGRL Surface Mount Back Box intended for compact horns, horn strobes and strobes.				

Ceiling Mounted Product	Diameter	Depth	Mounting Options
Strobe and Horn Strobe (including lens)	6.98" (177.3 mm)	2.16" (54.8 mm)	Two-Wire Outdoor Products: SBBCRL (ceiling), SBBCWL
Strobe and Horn Strobe (including lens) with SBBCRL Surface Mount Back Box	6.98" (177.3 mm)	4.66" (118.4 mm)	

NOTICE: This manual shall be left with the owner/user of this equipment.

1.3 Before Installing

Please read the System Sensor Audible Visible Application Reference Guide, which provides detailed information on notification devices, wiring and special applications. Copies of this manual are available from System Sensor. NFPA 72, UL50E/NEMA, and CAN/ULC S524 guidelines should be observed.

Important: The notification appliance used must be tested and maintained following requirements of NFPA 72 in UL applications or CAN/ULC S536 in ULC applications.

1.4 General Description

System Sensor series of notification appliances offer a wide range of audible and visible devices for life safety notification. Our two-wire horn strobes and strobes come with 8 field selectable tone and volume combinations and 7 field selectable candela settings. The new L-Series with LED outdoor notification appliances are designed to be used over a wider range of temperatures and are suitable for use in wet locations. **The devices are intended for outdoor applications and approved for wall-mount and ceiling-mount installations.**

Two-wire horn strobes and strobes are public mode notification appliances intended to alert occupants of a life safety event. The horn is listed to ANSI/UL 464/ULC 525 requirements (public mode) and the strobe is listed to ANSI/UL 1638/ULC 526 (public mode).

System Sensor notification appliances are designed to be used in 24VDC systems. System Sensor AV devices can be activated by a compatible fire alarm control panel or power supply. Refer to the appropriate fire alarm control panel or power supply manual for more information.

System Sensor two-wire horn strobes and strobes are electrically backward compatible with the previous generation of notification appliances; new back plates can be connected to existing wires from the FACP. They come enabled with System Sensor synchronization protocol which requires connections to a power supply capable of generating the System Sensor synchronization pulses, a FACP Notification Appliance Circuit (NAC) output configured to System Sensor synchronization protocol, or the use of synchronization module to generate the synchronization protocol.

1.5 Fire Alarm System Considerations

The National Fire Alarm and Signaling Code, NFPA 72, and The National Building Code of Canada require that all notification appliances used for building evacuation produce temporal coded signals. Signals other than those used for evacuation purposes do not have to produce the temporal coded signal. System Sensor recommends spacing notification appliances in compliance with NFPA 72 (UL applications) or CAN/ULC S524 (ULC applications).

1.6 System Design

The system designer must make sure that the total current draw by the devices on the loop does not exceed the current capability of the panel supply, and that the last device on the circuit is operated within its rated voltage. The current draw information for making these calculations can be found in the tables within the manual. For convenience and accuracy, use the voltage drop calculator on the System Sensor website (www.systemsensor.com).

When calculating the voltage available to the last device, it is necessary to consider the voltage due to the resistance of the wire. The thicker the wire, the smaller the voltage drop. Wire resistance tables can be obtained from electrical handbooks. Note that if Class A wiring is installed, the wire length may be up to twice as long as it would be for circuits that are not fault tolerant. The total number of strobes on a single NAC must not draw more current than supported by the FACP.

Wiring terminals or leads corresponding to the rating of the device shall be provided for connection of conductors of at least the size required by:

- a) In Canada only: CSA22.1, Section, Section 32, Fire alarm systems, smoke alarms, carbon monoxide alarms, and fire pumps.
- b) In the United States only: NFPA 70.

Section 2: Configurations for Notification Appliances

2.1 Available Tones

System Sensor offers a wide variety of tones for your life safety needs. Temporal 3 pattern is specified by ANSI and NFPA 72 for standard emergency evacuation signaling: ½ second on, ½ second off, ½ second on, ½ second off, ½ second on, 1½ off, and repeat.

To select the tone, turn the rotary switch on the back of the product to the desired setting. (See Figure 1.)

Available horn settings can be found in Table 1.

2.2 Available Candela Settings

System Sensor offers a wide range of candela settings for your life safety needs. To select your candela output, turn the rotary switch on the back of the product to the desired candela setting. (See Figure 2.) Table 2 shows available candela options.

The candela setting can be verified from the front of the unit by looking through a small window on the front of the product. (See Figure 13 for window location on device.) All products meet the light output profiles specified in the appropriate UL Standards. (See Figures 3, 4, and 5.)

To calculate sound dispersal per UL464 or ULC 525, refer to Table 4.

Figure 1 Audio Selector



A0621-00

Figure 2 Candela Selector

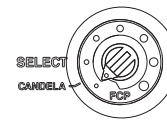

A0622-00

Table 1 Horn Tones

Pos	Tone	Volume Setting
1	Temporal 3	High
2	Temporal 3	Low
3	Non-Temporal	High
4	Non-Temporal	Low
5	3.1 KHz Temporal 3	High
6	3.1 KHz Temporal 3	Low
7	3.1 KHz Non-Temporal	High
8	3.1 KHz Non-Temporal	Low

Figure 3 Light Output –Horizontal Dispersion

Degrees*	Percent of Rating
0	100
5-25	90
30-45	75
50	55
55	45
60	40
65	35
70	35
75	30
80	30
85	25
90	25
Compound 45 to the left	24
Compound 45 to the right	24

*Tolerance of ±1 degree is permitted.

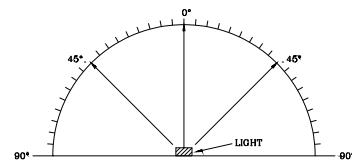

A0467-00

Figure 4 Light Output – Vertical Dispersion, Wall to Floor

Degrees*	Percent of Rating
0	100
5-30	90
35	65
40	46
45	34
50	27
55	22
60	18
65	16
70	15
75	13
80	12
85	12
90	12

*Tolerance of ±1 degree is permitted.

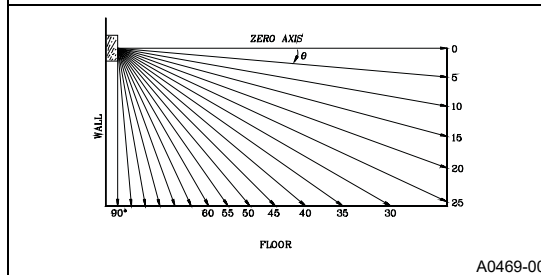
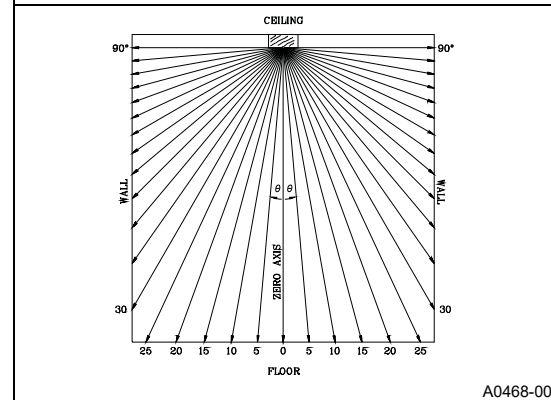

Figure 5 Light Output – Vertical Dispersion, Ceiling to Walls to Floor

Degrees*	Percent of Rating
0	100
5-25	90
30-45	75
50	55
60	45
65	35
70	35
75	30
80	30
85	25
90	25

*Tolerance of ±1 degree is permitted.



2.3 Current Draw and Audibility ratings

For the strobe, the current draw for each setting is listed in Table 2. For the horn strobe, the current draw and audibility settings are listed in Table 3. Reference binational harmonized standard UL 464/ULC 525 for minimum sound level requirements.

Table 2 UL/ULC Maximum Strobe Current Draw (mA)

Candela Rating	16-33 VDC	
	Wall	Ceiling
15	18	18
30	22	22
75	70	70
95	75	75
110	85	—
115	—	90
135	105	—
150	—	110
177	—	115
185	120	—
FCP*	(future)	(future)

*FCP Fire Control panel, future use

Table 3 UL/ULC Maximum Horn Strobe Current Draw (mA) and Sound Output (dBA)

			Current Draw (mA RMS), Horn Strobe, Candela Range (15-185 cd), FCP*										Sound Output (dBA)
Pos	Tone	Volume Setting	16-33 Volts										16-33 V
			15cd	30cd	75cd	95cd	110cd WALL	115cd CEILING	135cd WALL	150cd CEILING	177cd CEILING	185cd WALL	DC
1	Temporal	High	35	38	87	92	94	120	189	189	190	190	85
2	Temporal	Low	35	38	87	92	94	120	135	135	145	145	77
3	Non-Temporal	High	50	52	87	92	94	120	127	127	135	135	85
4	Non-Temporal	Low	35	38	87	92	94	120	125	125	130	130	77
5	3.1 KHz Temporal 3	High	35	38	87	89	91	115	155	155	165	165	82
6	3.1 KHz Temporal 3	Low	35	38	87	89	91	115	128	130	135	135	75
7	3.1 KHz Non-Temporal	High	40	42	87	89	91	115	125	125	135	135	82
8	3.1 KHz Non-Temporal	Low	35	38	87	89	91	115	120	120	130	130	75

Table 4 Directional Characteristics

Horizontal Axis	
Angle	Decibel loss (dBA)
0° (ref)	0 (ref)
+/- 65	-3
+/- 75	-6
Vertical Axis	
Angle	Decibel loss (dBA)
0° (ref)	0 (ref)
+/- 65	-3
N/A, no drop	-6

Section 3: Installation

3.1 Wiring and Mounting

All wiring must be installed in compliance with the National Electric Code (UL applications), (Canadian Electric Code (ULC applications), and local codes as well as the authority having jurisdiction. Wiring must not be of such length or wire size which would cause the notification appliance to operate outside of its published specifications. Improper connections can prevent the system from alerting occupants in the event of an emergency.

The gasketed back plate ships with wire leads stripped and installed at the factory; weatherproof wire nuts are required and provided. Wire sizes up to 12 AWG (2.5 mm²) may be used for field wiring.

Make wire connections by stripping about $\frac{3}{8}$ " of insulation from the end of the field wire. Then twist the bare end of the field wire with respective back plate wire lead and secure the wiring by twisting a weatherproof wire nut into place.

3.2 Wiring Diagrams

The two-wire horn strobe and strobe only require two wires for power and supervision. (See Figure 7.) Please consult your FACP manufacturer or power supply manufacturer for specific wiring configurations and special cases.

Figure 6 Wiring Terminals and Wire Leads

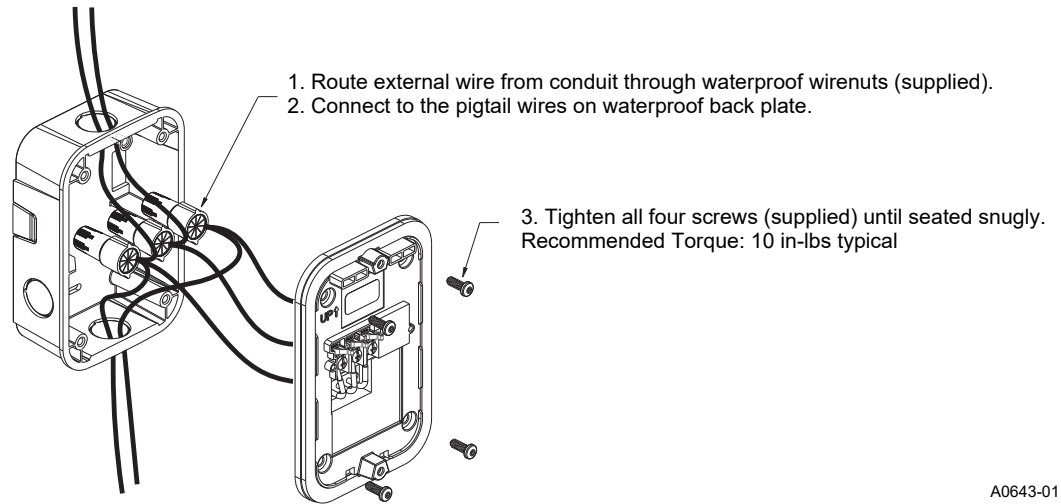

A0643-01

Figure 7 System Wiring

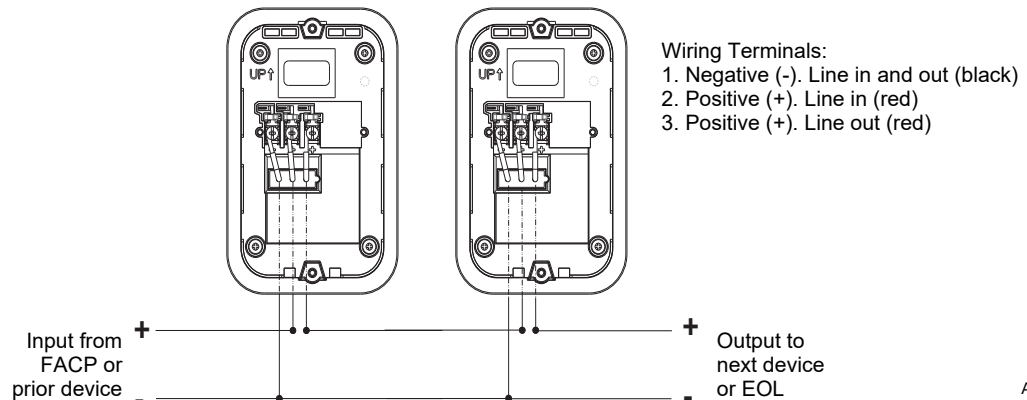

A0644-00

3.3 Install Back Box

1. Attach surface mount back box directly to wall or ceiling. Use of grounding bracket with ground screw is optional. (See Figures 8 and 9.)
2. Mounting position:
 - **Note for positioning:** *Wall mount back boxes:* Mount with the up arrow pointing up. (See Figure 11.)
 - **Note for positioning:** *Ceiling mount back boxes:* Ceiling surface mount back box SBBCR is a common back box for ceiling horn strobes, strobes, speakers, and speaker strobes. Use the top (SPK) mounting holes for ceiling speaker and speaker strobe products. Use the bottom (STR) mounting holes for ceiling horn strobe, and strobe installation needs. (See Figure 10.)
3. Select appropriate knockouts and open as needed.

- Threaded knockout holes are provided for the sides of the box for 3/4 inch and 1/2 inch conduit adapter. Knockout holes in the back of the box can be used for 3/4 inch and 1/2 inch rear entry.
- If using the 3/4 inch knockout: To remove the 3/4 inch knockout, place the blade of a flat-head screwdriver along the outer edge and work your way around the knockout as you strike the screwdriver. (See Figure 12.)
NOTE: Use caution not to strike the knockout near the top edge of the surface mount back box.
- V500 and V700 raceway knockouts are also provided. Use V500 for low profile applications and V700 for high profile applications. To remove the knockout, turn pliers up. (See Figure 12.)

3.4 Install Weatherproof Back Plate and Appliance

1. Connect field wiring to wire leads according to terminal designations on weatherproof back plate using the provided weatherproof wire nuts. (See Figures 6 and 7.)
2. Attach weatherproof back plate to the surface mount back box using the four Philips head screws provided. (See Figures 8 – 9.)
 - Ceiling mount back boxes: Use the top (SPK) mounting holes; screw position will ensure correct alignment. (See Figure 10.)
3. If the product is not to be installed at this point, use the protective dust cover to prevent contamination of the wiring terminals on the mounting plate.
4. To attach product to weatherproof back plate:
 - Remove the protective dust cover.
 - Align the product housing with the guideposts located on the weatherproof back plate.
 - Slide the product into position to engage the terminals on the weatherproof back plate.
 - Hold product in place with one hand, and secure product by tightening the mounting screws on the front of the housing.
NOTE: Wall models have 2 screws. (See Figure 8.) Ceiling models have 3 screws. (See Figure 9.)
 - Tighten the screws by hand to ensure screws are completely engaged.



CAUTION:

Factory finish should not be altered: Do not paint!

Figure 8 Surface Mounting an Outdoor Wall Device with SBBGRL

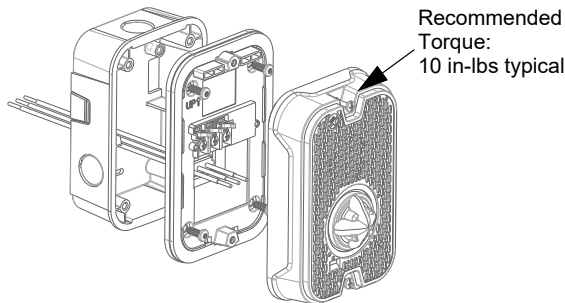

A0627-00

Figure 9 Surface Mounting an Outdoor Ceiling Device with SBBCRL

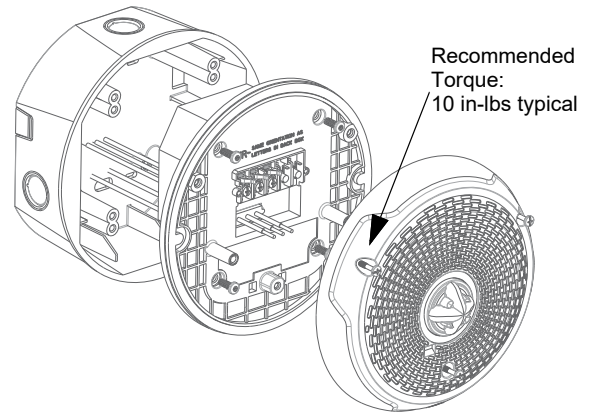

A0628-00

Figure 10 Selecting screw location in a ceiling installation of a surface-mount back box

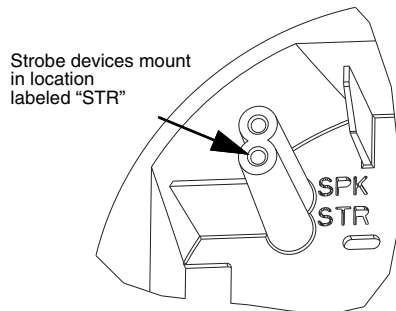

A0505-01

Figure 11 Surface Mount Back Box “Up” Arrow

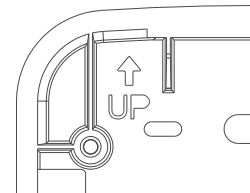

A0481-00

Figure 12 Knockout and V500/V700 Removal for Surface Mount Back Box

Figure 12A Knockout size

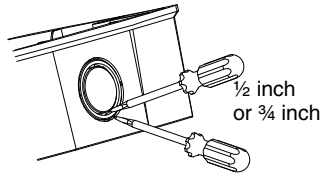

A0465-01

Figure 12B Wire Mold Removal

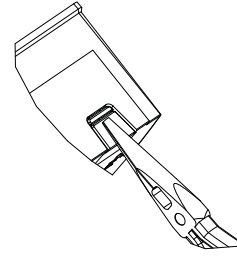

A0466-01

NOTE: Use caution not to strike the knockout near the top edge of the wall version of the surface mount back box.

Figure 13 Candela Window Location

Wall Mounted

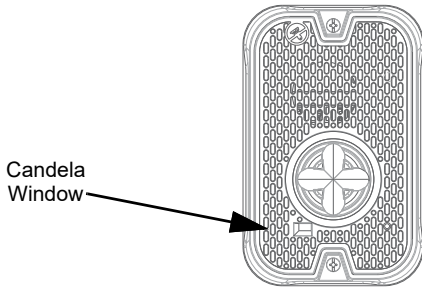

A0636-00

Ceiling Mounted

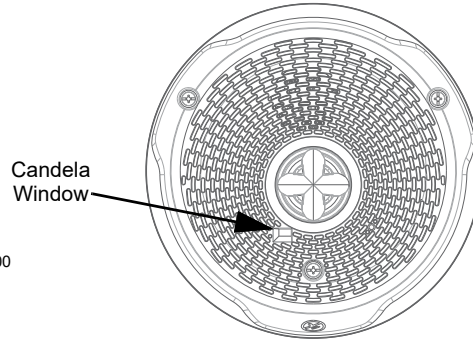

A0637-00



THE LIMITATIONS OF HORN/STROBES

The horn and/or strobe will not work without power. The horn/strobe gets its power from the fire/security panel monitoring the alarm system. If power is cut off for any reason, the horn/strobe will not provide the desired audio or visual warning.
The horn may not be heard. The loudness of the horn meets (or exceeds) current Underwriters Laboratories' standards. However, the horn may not alert a sound sleeper or one who has recently used drugs or has been drinking alcoholic beverages. The horn may not be heard if it is placed on a different floor from the person in hazard or if placed too far away to be heard over the ambient noise such as traffic, air conditioners, machinery or music appliances that may prevent alert persons from hearing the alarm. The horn may not be heard by persons who are hearing impaired.

NOTE: Strobes must be powered continuously for horn operation.
The signal strobe may not be seen. The electronic visual warning signal uses LEDs

with associated lens system. It flashes at least once every second. The strobe must not be installed in direct sunlight or areas of high light intensity (over 60 foot candles) where the visual flash might be disregarded or not seen. The strobe may not be seen by the visually impaired.
The signal strobe may cause seizures. Individuals who have positive photoic response to visual stimuli with seizures, such as persons with epilepsy, should avoid prolonged exposure to environments in which strobe signals, including this strobe, are activated.
The signal strobe cannot operate from coded power supplies. Coded power supplies produce interrupted power. The strobe must have an uninterrupted source of power in order to operate correctly. System Sensor recommends that the horn and signal strobe always be used in combination so that the risks from any of the above limitations are minimized.

FCC Statement

This equipment has been tested and found to comply with the limits for a Class B digital device, pursuant to part 15 of the FCC Rules. These limits are designed to provide reasonable protection against harmful interference in a residential installation. This equipment generates, uses and can radiate radio frequency energy and, if not installed and used in accordance with the instructions, may cause harmful interference to radio communications. However, there is no guarantee that interference will not occur in a particular installation. If this equipment does cause harmful interference to radio or television reception, which can be determined by turning the equipment off

and on, the user is encouraged to try to correct the interference by one or more of the following measures:
-Reorient or relocate the receiving antenna.
-Increase the separation between the equipment and receiver.
-Connect the equipment into an outlet on a circuit different from that to which the receiver is connected.
-Consult the dealer or an experienced radio/TV technician for help.
This Class B digital apparatus complies with Canadian ICES-003.



This symbol (shown left) on the product(s) and / or accompanying documents means that used electrical and electronic products should not be mixed with general household waste. For proper treatment, recovery and recycling, contact your local authorities or dealer and ask for the correct method of disposal.
Electrical and electronic equipment contains materials, parts and substances, which can be dangerous to the environment and harmful to human health if the waste of electrical and electronic equipment (WEEE) is not disposed of correctly.

Supplemental Information

For the latest Warranty information, please go to:
<http://www.systemsensor.com/en-us/Documents/E56-4000.pdf>
For Limitations of Fire Alarm Systems, please go to:
<http://www.systemsensor.com/en-us/Documents/I56-1558.pdf>
Speakers only: For the latest Important Assembly Information, please go to:
<http://www.systemsensor.com/en-us/Documents/I56-6556.pdf>



Warranty Information



Limitations of Fire Alarm Systems



Speakers Only: Assembly Information

System Sensor® is a registered trademark of Honeywell International, Inc.
©2024 System Sensor.