

# MI-DCMO

# ADDRESSABLE CONTROL

# OUTPUT MODULE

The Morley-IAS MI-DCMO control output module is used with the ZX series of intelligent control panels to provide either a single alarm circuit or Form C relay.

The MI-DCMO can be used to operate dry contacts for door holders, air handling unit shut down or other similar functions. Optionally the module can be used to supervise wiring to the output load providing monitoring of the external load voltage or power supply. If the monitored voltage falls below threshold then a fault condition will be indicated.

Each MI-DCMO uses one of the ninety-nine possible module addresses available on a loop. It responds to regular polling from the control panel indicated by a pulsing LED every successful communication. On command from the control panel the MI-DCMO will disconnect the supervision and connect the external power supply across the load. The disconnection of the supervision provides a positive indication to the control panel that the relay is activated. The MI-DCMO has a

built-in isolator which may be switched out if required.

The MI-DCMO uses a unique mechanical design allowing each module to be mounted either in a wall box (M200-SMB) or on a DIN rail (using M200-DIN). Irrespective of the mounting method chosen, the address switch is both visible and accessible for selection. To help engineers in the maintenance and fault finding process, both the LEDs and the address switches can be viewed without having to remove the cover of the mounting box. The LEDs, being multi colour, provide diagnostic information regarding the status of the output. For ease of installation, testing and maintenance, the field wiring terminals are of a plug in design.

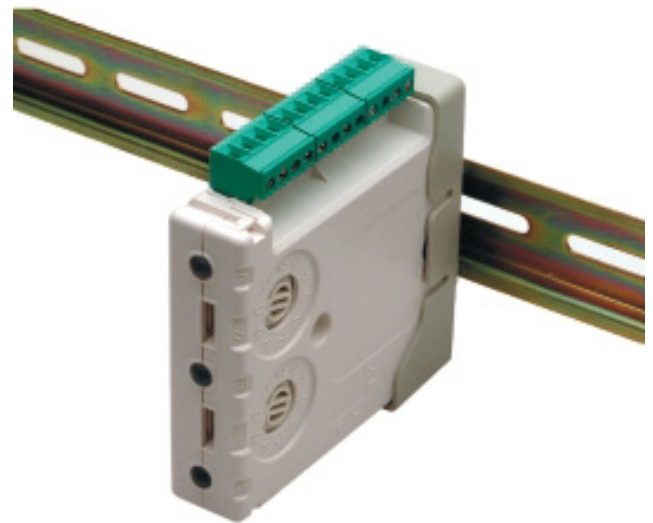

## FEATURES

- DIN rail mounting option
- Surface mounting option
- Tri-colour LED status indication
- Built-in Short Circuit Isolators
- Visible Address selector switches
- LED status visible in 2 planes
- Plug in connectors
- Approved to GEA GEI 1-082 and CEA GEI 1-084

# MI-DCMO SPECIFICATIONS

## Mechanical Specifications

Dimensions (H x W x D)	93 x 94 x 23 (mm)
Weight	110g
Operating Temperature	-20 °C to +60 °C
Relative Humidity	0 to 95% maximum non-condensing

## Electrical Specifications

Operating voltage	15 to 30 Vdc
-------------------	--------------

## Standby current

No comms	310µA at 24 Vdc maximum
1 comms every 5 seconds with LED blink	510µA at 24 Vdc maximum
Terminal Wire	2.5 mm <sup>2</sup> maximum

## Relay Form C

Unsupervised	2A at 30 Vdc, resistive load.
Supervised	1.5A at 30 Vdc, resistive load.

## Part Numbers

MI-DCMO	Single channel addressable output module
---------	--

## Accessories

M200E-SMB	Surface mounting box
M200E-DIN	DIN rail mounting clip

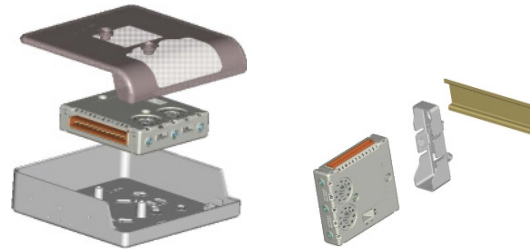
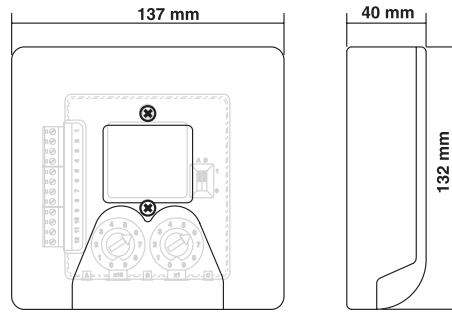
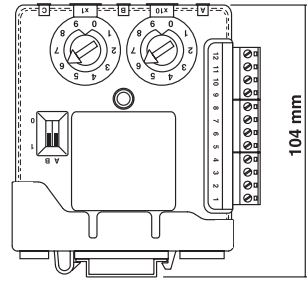
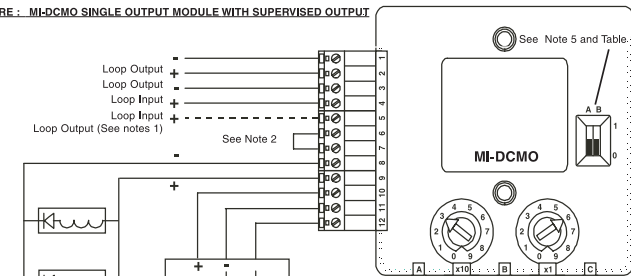

FIGURE 1: MI-DCMO SINGLE OUTPUT MODULE WITH SUPERVISED OUTPUT



### Notes:

- 1 If short circuit isolation is not required, loop output+ should be wired to terminal 5 and not 2. Terminal 5 is internally connected to terminal 4.
- 2 To enable output circuit supervision, the link supplied must be fitted across terminals 6 and 7, and the load must be polarised.
- 3 In supervised mode, the module monitors the power supply voltage across terminals 10 and 11 to ensure it does not drop below 7V, and also monitors for a switched negative fault signal from the power supply to terminal 12 (optional). If a fault is seen the yellow LED will blink, and a fault may be indicated at the panel.
- 4 Up to 1.5A load can be driven subject to the supply capability, total cable resistance and minimum voltage required by the load.
- 5 An alternative end of line monitoring option is available for VdS 2489 requirements - see table 1. Maximum cable series resistance is 10R so max. load current is limited by permissible voltage drop along the cable, min. PSU voltage and min. load voltage requirement, eg: Min PSU voltage = 21V, min load voltage = 18V, max. series resistance = 10R, therefore max. current = 300mA [(21-18)/10 Amps].

Table 1: EOL Monitoring Options

Mode	Switch A Position	Switch B Position	EOL Device	Load
Std	0	0	47k Resistor	See Note 4
VdS	1	0	Polarised 47R	See Note 5
RLY	N/A	1	Unsupervised	

FIGURE 2: MI-DCMO SINGLE OUTPUT MODULE WITH UNSUPERVISED OUTPUT

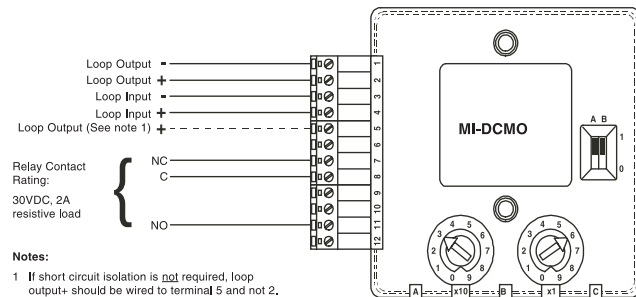

### Notes:

- 1 If short circuit isolation is not required, loop output+ should be wired to terminal 5 and not 2. Terminal 5 is internally connected to terminal 4.

## For more information,

<https://honeywellbuildings.in>

Call: 1-800-103-0339

Email: [HBT-Indiabuildings@honeywell.com](mailto:HBT-Indiabuildings@honeywell.com)

## Honeywell HBT India Buildings

Unitech Trade Center, 5th Floor, Sector-43,  
Block C, Sushant Lok Phase - I,  
Gurgaon - 122 002

[www.honeywell.com](http://www.honeywell.com)

© 2020 Honeywell International Inc.

**MI-DCMO**  
**ADDRESSABLE CONTROL**  
**OUTPUT MODULE**

**Honeywell**